

## HIGHLIGHTS OF PRESCRIBING INFORMATION

These highlights do not include all the information needed to use PROGRAF safely and effectively. See full prescribing information for PROGRAF.

PROGRAF® (tacrolimus) capsules, USP

PROGRAF® (tacrolimus) injection, (for intravenous use)

Initial U.S. Approval: 1994

### WARNING: MALIGNANCIES AND SERIOUS INFECTIONS

See full prescribing information for complete boxed warning

- Increased risk of development of lymphoma and other malignancies, particularly of the skin, due to immunosuppression (5.2)
- Increased susceptibility to bacterial, viral, fungal, and protozoal infections, including opportunistic infections (5.3, 5.4, 5.5)
- Only physicians experienced in immunosuppressive therapy and management of organ transplant patients should prescribe Prograf (5.1)

### INDICATIONS AND USAGE

Prograf is a calcineurin-inhibitor immunosuppressant indicated for

- Prophylaxis of organ rejection in patients receiving allogeneic liver, kidney or heart transplants (1.1, 1.2, 1.3)
- Use concomitantly with adrenal corticosteroids; in kidney and heart transplant, use in conjunction with azathioprine or mycophenolate mofetil (MMF) (1.1, 1.2, 1.3)
- Limitations of Use (1.4):
  - Do not use simultaneously with cyclosporine
  - Intravenous use reserved for patients who can not tolerate capsules orally
  - Use with sirolimus is not recommended in liver and heart transplant; use with sirolimus in kidney transplant has not been established

### DOSAGE AND ADMINISTRATION

Summary of Initial Oral Dosage Recommendation and Observed Whole Blood Trough Concentrations (2.1, 2.2).

| Patient Population  | Recommended Initial Oral Dosage (two divided doses every 12 hours) | Observed Whole Blood Trough Concentrations       |
|---|--|--|
| Adult Kidney transplant<br>In combination with azathioprine | 0.2 mg/kg/day  | month 1-3: 7-20 ng/mL<br>month 4-12: 5-15 ng/mL  |
| In combination with MMF/IL-2 receptor antagonist            | 0.1 mg/kg/day  | month 1-12: 4-11 ng/mL                           |
| Adult Liver transplant<br>Pediatric Liver transplant        | 0.10-0.15 mg/kg/day<br>0.15-0.20 mg/kg/day                         | month 1-12: 5-20 ng/mL<br>month 1-12: 5-20 ng/mL |
| Adult Heart transplant                                      | 0.075 mg/kg/day  | month 1-3: 10-20 ng/mL<br>month ≥4: 5-15 ng/mL   |

- Careful and frequent monitoring of tacrolimus trough concentrations is recommended; Black patients may require higher doses in order to achieve comparable trough concentrations (2.1)
- Hepatic/Renal impaired patients should receive doses at the lowest value of the recommended initial oral dosing range (2.3, 2.4)
- Administer capsules consistently with or without food; do not drink grapefruit juice (2.5, 7.2)

### DOSAGE FORMS AND STRENGTHS

- Capsules: 0.5 mg, 1 mg and 5 mg (3)
- Injection: 5 mg/mL (3)

### CONTRAINDICATIONS

- Hypersensitivity to tacrolimus or HCO-60 (polyoxyl 60 hydrogenated castor oil) (4)

### WARNINGS AND PRECAUTIONS

- Lymphoma and Other Malignancies: Risk of lymphomas, including post transplant lymphoproliferative disorder (PLTD); appears related to intensity and duration of use. Avoid prolonged exposure to UV light and sunlight (5.2)

- Serious infections: Increased risk of bacterial, viral, fungal and protozoal infections, including opportunistic infections: combination immunosuppression should be used with caution (5.3)
- Polyoma Virus Infections: Serious, sometimes fatal outcomes, including polyoma virus-associated nephropathy (PVAN), mostly due to BK virus, and JC virus-associated progressive multifocal leukoencephalopathy (PML); consider reducing immunosuppression (5.4)
- Cytomegalovirus (CMV) Infections: Increased risk of CMV viremia and disease; consider reducing immunosuppression (5.5)
- New Onset Diabetes After Transplant: Monitor blood glucose (5.6)
- Nephrotoxicity: Acute and/or chronic; reduce the dose; use caution with other nephrotoxic drugs (5.7)
- Neurotoxicity: Risk of Posterior Reversible Encephalopathy Syndrome, monitor for neurologic abnormalities; reduce or discontinue Prograf and other immunosuppressants (5.8)
- Hyperkalemia: Monitor serum potassium levels. Careful consideration should be given prior to use of other agents also associated with hyperkalemia (5.9)
- Hypertension: May require antihypertensive therapy. Monitor relevant drug-drug interactions (5.10)
- Anaphylactic Reactions with IV formulation: Observe patients receiving Prograf injection for signs and symptoms of anaphylaxis (5.11)
- Use with Sirolimus: Not recommended in liver and heart transplant due to increased risk of serious adverse reactions (5.12)
- Myocardial Hypertrophy: Consider dosage reduction or discontinuation (5.15)
- Immunizations: Use of live vaccines should be avoided (5.16)
- Pure Red Cell Aplasia: Discontinuation should be considered (5.17)

### ADVERSE REACTIONS

- Kidney Transplant: The most common adverse reactions (≥ 30%) were infection, tremor, hypertension, abnormal renal function, constipation, diarrhea, headache, abdominal pain, insomnia, nausea, hypomagnesemia, urinary tract infection, hypophosphatemia, peripheral edema, asthenia, pain, hyperlipidemia, hyperkalemia, anemia (6.1)
- Liver Transplant: The most common adverse reactions (≥ 40%) were tremor, headache, diarrhea, hypertension, nausea, abnormal renal function, abdominal pain, insomnia, paresthesia, anemia, pain, fever, asthenia, hyperkalemia, hypomagnesemia, and hyperglycemia (6.1)
- Heart Transplant: The most common adverse reactions (≥ 15%) were abnormal renal function, hypertension, diabetes mellitus, CMV infection, tremor, hyperglycemia, leukopenia, infection, anemia, bronchitis, pericardial effusion, urinary tract infection and hyperlipemia (6.1)

To report SUSPECTED ADVERSE REACTIONS, contact Astellas Pharma US, Inc at 1-800-727-7003 or FDA at 1-800-FDA-1088 or [www.fda.gov/medwatch](http://www.fda.gov/medwatch)

### DRUG INTERACTIONS

- Mycophenolic Acid Products: Can increase MPA exposure after crossover from cyclosporine to Prograf; monitor for MPA-related adverse reactions and adjust MMF or MPA-dose as needed (7.1)
- Nelfinavir and Grapefruit Juice: Increased tacrolimus concentrations via CYP3A inhibition; avoid concomitant use (7.2, 7.3)
- CYP3A Inhibitors: Increased tacrolimus concentrations; monitor concentrations and adjust tacrolimus dose as needed with concomitant use (5.13, 7.3, 7.4, 7.5, 7.6)
- CYP3A4 Inducers: Decreased tacrolimus concentrations; monitor concentrations and adjust tacrolimus dose as needed with concomitant use (5.13, 7.7, 7.8, 7.9)

### USE IN SPECIFIC POPULATIONS

- Pregnancy: Based on animal data may cause fetal harm. Use only if the potential benefit justifies the risk (8.1)
- Nursing Mothers: Discontinue nursing taking into consideration importance of drug to mother (8.3)
- Hepatic/Renal impaired patients: Administer at the lower end of the recommended starting dose. Monitor renal function in patients with impaired renal function (2.3, 2.4, 8.6, 8.7)

See 17 for PATIENT COUNSELING INFORMATION

Revision:05/2015

---

**FULL PRESCRIBING INFORMATION: CONTENTS\*****WARNING: MALIGNANCIES AND SERIOUS INFECTIONS****1 INDICATIONS AND USAGE**

- 1.1 Prophylaxis of Organ Rejection in Kidney Transplant
- 1.2 Prophylaxis of Organ Rejection in Liver Transplant
- 1.3 Prophylaxis of Organ Rejection in Heart Transplant
- 1.4 Limitations of Use

**2 DOSAGE AND ADMINISTRATION**

- 2.1 Dosage in Adult Kidney, Liver, or Heart Transplant Patients
- 2.2 Dosage in Pediatric Liver Transplant Patients
- 2.3 Dosage Adjustment in Patients with Renal Impairment
- 2.4 Dosage Adjustments in Patients with Hepatic Impairment
- 2.5 Administration Instructions
- 2.6 Therapeutic Drug Monitoring
- 2.7 Preparation for Intravenous Product

**3 DOSAGE FORMS AND STRENGTHS****4 CONTRAINDICATIONS****5 WARNINGS AND PRECAUTIONS**

- 5.1 Management of Immunosuppression
- 5.2 Lymphoma and Other Malignancies
- 5.3 Serious Infections
- 5.4 Polyoma Virus Infections
- 5.5 Cytomegalovirus (CMV) Infections
- 5.6 New Onset Diabetes After Transplant
- 5.7 Nephrotoxicity
- 5.8 Neurotoxicity
- 5.9 Hyperkalemia
- 5.10 Hypertension
- 5.11 Anaphylactic Reactions with Prograf Injection
- 5.12 Use with Sirolimus
- 5.13 Use with CYP3A4 Inhibitors and Inducers
- 5.14 QT Prolongation
- 5.15 Myocardial Hypertrophy
- 5.16 Immunizations
- 5.17 Pure Red Cell Aplasia
- 5.18 Gastrointestinal Perforation

**6 ADVERSE REACTIONS**

- 6.1 Clinical Studies Experience
- 6.2 Postmarketing Adverse Reactions

**7 DRUG INTERACTIONS**

- 7.1 Mycophenolic Acid Products
- 7.2 Grapefruit Juice
- 7.3 Protease Inhibitors
- 7.4 Antifungal Agents
- 7.5 Calcium Channel Blockers
- 7.6 Antibacterials
- 7.7 Antimycobacterials
- 7.8 Anticonvulsants
- 7.9 St. John's Wort (*Hypericum perforatum*)
- 7.10 Gastric Acid Suppressors/Neutralizers
- 7.11 Others

**8 USE IN SPECIFIC POPULATIONS**

- 8.1 Pregnancy
- 8.3 Nursing Mothers
- 8.4 Pediatric Use
- 8.5 Geriatric Use
- 8.6 Use in Renal Impairment
- 8.7 Use in Hepatic Impairment

**10 OVERDOSAGE****11 DESCRIPTION****12 CLINICAL PHARMACOLOGY**

- 12.1 Mechanism of Action
- 12.3 Pharmacokinetics

**13 NONCLINICAL TOXICOLOGY**

- 13.1 Carcinogenesis, Mutagenesis, Impairment of Fertility

**14 CLINICAL STUDIES**

- 14.1 Kidney Transplantation
- 14.2 Liver Transplantation
- 14.3 Heart Transplantation

**16 HOW SUPPLIED/STORAGE AND HANDLING**

- 16.1 Prograf (tacrolimus) Capsules
- 16.2 Prograf (tacrolimus) Injection

**17 PATIENT COUNSELING INFORMATION**

- 17.1 Administration
- 17.2 Development of Lymphoma and Other Malignancies
- 17.3 Increased Risk of Infection
- 17.4 New Onset Diabetes After Transplant
- 17.5 Nephrotoxicity
- 17.6 Neurotoxicity
- 17.7 Hyperkalemia
- 17.8 Hypertension
- 17.9 Drug Interactions
- 17.10 Pregnant Women and Nursing Mothers
- 17.11 Immunizations

---

\*Sections or subsections omitted from the full prescribing information are not listed

## FULL PRESCRIBING INFORMATION

### BOXED WARNING – MALIGNANCIES AND SERIOUS INFECTIONS

- **Increased risk of development of lymphoma and other malignancies, particularly of the skin, due to immunosuppression [see Warnings and Precautions (5.2)].**
- **Increased susceptibility to bacterial, viral, fungal, and protozoal infections, including opportunistic infections [see Warnings and Precautions (5.3, 5.4, 5.5)].**
- **Only physicians experienced in immunosuppressive therapy and management of organ transplant patients should prescribe Prograf. Patients receiving the drug should be managed in facilities equipped and staffed with adequate laboratory and supportive medical resources. The physician responsible for maintenance therapy should have complete information requisite for the follow-up of the patient [see Warnings and Precautions (5.1)].**

## 1 INDICATIONS AND USAGE

### 1.1 Prophylaxis of Organ Rejection in Kidney Transplant

Prograf is indicated for the prophylaxis of organ rejection in patients receiving allogeneic kidney transplants. It is recommended that Prograf be used concomitantly with azathioprine or mycophenolate mofetil (MMF) and adrenal corticosteroids [see *Clinical Studies (14.1)*]. Therapeutic drug monitoring is recommended for all patients receiving Prograf [see *Dosage and Administration (2.6)*].

### 1.2 Prophylaxis of Organ Rejection in Liver Transplant

Prograf is indicated for the prophylaxis of organ rejection in patients receiving allogeneic liver transplants. It is recommended that Prograf be used concomitantly with adrenal corticosteroids [see *Clinical Studies (14.2)*]. Therapeutic drug monitoring is recommended for all patients receiving Prograf [see *Dosage and Administration (2.6)*].

### 1.3 Prophylaxis of Organ Rejection in Heart Transplant

Prograf is indicated for the prophylaxis of organ rejection in patients receiving allogeneic heart transplants. It is recommended that Prograf be used concomitantly with azathioprine or mycophenolate mofetil (MMF) and adrenal corticosteroids [see *Clinical Studies (14.3)*]. Therapeutic drug monitoring is recommended for all patients receiving Prograf [see *Dosage and Administration (2.6)*].

### 1.4 Limitations of Use

Prograf should not be used simultaneously with cyclosporine [see *Dosage and Administration (2.5)*].

Prograf injection should be reserved for patients unable to take Prograf capsules orally [see *Dosage and Administration (2.1)* and *Warnings and Precautions (5.11)*].

Use with sirolimus is not recommended in liver and heart transplant. The safety and efficacy of Prograf with sirolimus has not been established in kidney transplant [see *Warnings and Precautions (5.12)*].

## 2 DOSAGE AND ADMINISTRATION

### 2.1 Dosage in Adult Kidney, Liver, or Heart Transplant Patients

The initial oral dosage recommendations for adult patients with kidney, liver, or heart transplants along with recommendations for whole blood trough concentrations are shown in Table 1. The initial dose of Prograf should be administered no sooner than 6 hours after transplantation in the liver and heart transplant patients. In kidney transplant patients, the initial dose of Prograf may be administered within 24 hours of transplantation, but should be delayed until renal function has recovered. For blood concentration monitoring details see Dosage and Administration (2.6).

**Table 1. Summary of Initial Oral Dosage Recommendations and Observed Whole Blood Trough Concentrations in Adults**

| Patient Population  | Recommended Prograf Initial Oral Dosage<br>Note: daily doses should be administered as two divided doses, every 12 hours | Observed Tacrolimus Whole Blood Trough Concentrations |
|---|--|---|
| Adult kidney transplant patients                              |  |   |
| In combination with azathioprine                              | 0.2 mg/kg/day  | month 1-3: 7-20 ng/mL<br>month 4-12: 5-15 ng/mL       |
| In combination with MMF/IL-2 receptor antagonist <sup>a</sup> | 0.1 mg/kg/day  | month 1-12: 4-11 ng/mL                                |
| Adult liver transplant patients                               | 0.10-0.15 mg/kg/day  | month 1-12: 5-20 ng/mL                                |
| Adult heart transplant patients                               | 0.075 mg/kg/day  | month 1-3: 10-20 ng/mL<br>month $\geq$ 4: 5-15 ng/mL  |

<sup>a)</sup> In a second smaller trial, the initial dose of tacrolimus was 0.15-0.2 mg/kg/day and observed tacrolimus concentrations were 6-16 ng/mL during month 1-3 and 5-12 ng/mL during month 4-12 [see *Clinical Studies (14.1)*].

Dosing should be titrated based on clinical assessments of rejection and tolerability. Lower Prograf dosages than the recommended initial dosage may be sufficient as maintenance therapy. Adjunct therapy with adrenal corticosteroids is recommended early post-transplant.

The data in kidney transplant patients indicate that the Black patients required a higher dose to attain comparable trough concentrations compared to Caucasian patients (Table 2).

**Table 2. Comparative Dose and Trough Concentrations Based on Race**

| Time After Transplant | Caucasian<br>n=114 |                                  | Black<br>n=56   |                                  |
|-----------------------|--------------------|----------------------------------|-----------------|----------------------------------|
|                       | Dose<br>(mg/kg)    | Trough Concentrations<br>(ng/mL) | Dose<br>(mg/kg) | Trough Concentrations<br>(ng/mL) |
| Day 7                 | 0.18               | 12.0                             | 0.23            | 10.9                             |
| Month 1               | 0.17               | 12.8                             | 0.26            | 12.9                             |
| Month 6               | 0.14               | 11.8                             | 0.24            | 11.5                             |
| Month 12              | 0.13               | 10.1                             | 0.19            | 11.0                             |

#### *Initial Dose – Injection*

Prograf injection should be used only as a continuous IV infusion and when the patient cannot tolerate oral administration of Prograf capsules. Prograf injection should be discontinued as soon as the patient can tolerate oral administration of Prograf capsules, usually within 2-3 days. In a patient receiving an IV infusion, the first dose of oral therapy should be given 8-12 hours after discontinuing the IV infusion.

The observed trough concentrations described above pertain to oral administration of Prograf only; while monitoring Prograf concentrations in patients receiving Prograf injection as a continuous IV infusion may have some utility, the observed concentrations will not represent comparable exposures to those estimated by the trough concentrations observed in patients on oral therapy.

The recommended starting dose of Prograf injection is 0.03-0.05 mg/kg/day in kidney and liver transplant and 0.01 mg/kg/day in heart transplant given as a continuous IV infusion. Adult patients should receive doses at the lower end of the dosing range. Concomitant adrenal corticosteroid therapy is recommended early post-transplantation.

Anaphylactic reactions have occurred with injectables containing castor oil derivatives, such as Prograf injection [see *Warnings and Precautions (5.11)*].

## 2.2 Dosage in Pediatric Liver Transplant Patients

The initial oral dosage recommendations for pediatric patients with liver transplants along with recommendations for whole blood trough concentrations are shown in Table 3. For blood concentration monitoring details see Dosage and Administration (2.6). If necessary, pediatric patients may start on an IV dose of 0.03-0.05 mg/kg/day.

**Table 3. Summary of Initial Oral Dosage Recommendations and Observed Whole Blood Trough Concentrations in Children**

| Patient Population                  | Recommended Prograf Initial Oral Dosage<br>Note: daily doses should be administered as two divided doses, every 12 hours | Observed Tacrolimus Whole Blood Trough Concentrations |
|-------------------------------------|--|---|
| Pediatric liver transplant patients | 0.15-0.20 mg/kg/day  | Month 1-12: 5-20 ng/mL                                |

Pediatric liver transplantation patients without pre-existing renal or hepatic dysfunction have required and tolerated higher doses than adults to achieve similar blood concentrations.

Experience in pediatric kidney and heart transplantation patients is limited.

## 2.3 Dosage Adjustment in Patients with Renal Impairment

Due to its potential for nephrotoxicity, consideration should be given to dosing Prograf at the lower end of the therapeutic dosing range in patients who have received a liver or heart transplant and have pre-existing renal impairment. Further reductions in dose below the targeted range may be required.

In kidney transplant patients with post-operative oliguria, the initial dose of Prograf should be administered no sooner than 6 hours and within 24 hours of transplantation, but may be delayed until renal function shows evidence of recovery.

## 2.4 Dosage Adjustments in Patients with Hepatic Impairment

Due to the reduced clearance and prolonged half-life, patients with severe hepatic impairment (Child Pugh  $\geq 10$ ) may require lower doses of Prograf. Close monitoring of blood concentrations is warranted.

The use of Prograf in liver transplant recipients experiencing post-transplant hepatic impairment may be associated with increased risk of developing renal insufficiency related to high whole-blood concentrations of tacrolimus. These patients should be monitored closely and dosage adjustments should be considered. Some evidence suggests that lower doses should be used in these patients [see *Dosage and Administration (2.1)*, *Use in Specific Populations (8.7)* and *Clinical Pharmacology (12.3)*].

## 2.5 Administration Instructions

It is recommended that patients initiate oral therapy with Prograf capsules if possible.

Initial dosage and observed tacrolimus whole blood trough concentrations for adults are shown in Table 1 and for pediatrics in Table 3 [*see Dosage and Administration (2.1, 2.2)*]; for blood concentration monitoring details in kidney transplant patients [*see Dosage and Administration (2.1)*].

It is important to take Prograf capsules consistently every day either with or without food because the presence and composition of food decreases the bioavailability of Prograf [*see Clinical Pharmacology (12.3)*].

Patients should not eat grapefruit or drink grapefruit juice in combination with Prograf [*see Drug Interactions (7.2)*].

Prograf should not be used simultaneously with cyclosporine. Prograf or cyclosporine should be discontinued at least 24 hours before initiating the other. In the presence of elevated Prograf or cyclosporine concentrations, dosing with the other drug usually should be further delayed.

In patients unable to take oral Prograf capsules, therapy may be initiated with Prograf injection as a continuous IV infusion. If IV therapy is necessary, conversion from IV to oral Prograf is recommended as soon as oral therapy can be tolerated. This usually occurs within 2-3 days. In patients receiving an IV infusion, the first dose of oral therapy should be given 8-12 hours after discontinuing the IV infusion.

## 2.6 Therapeutic Drug Monitoring

Monitoring of tacrolimus blood concentrations in conjunction with other laboratory and clinical parameters is considered an essential aid to patient management for the evaluation of rejection, toxicity, dose adjustments and compliance. Observed whole blood trough concentrations can be found in Table 1. Factors influencing frequency of monitoring include but are not limited to hepatic or renal dysfunction, the addition or discontinuation of potentially interacting drugs and the post-transplant time. Blood concentration monitoring is not a replacement for renal and liver function monitoring and tissue biopsies. Data from clinical trials show that tacrolimus whole blood concentrations were most variable during the first week post-transplantation.

The relative risks of toxicity and efficacy failure are related to tacrolimus whole blood trough concentrations. Therefore, monitoring of whole blood trough concentrations is recommended to assist in the clinical evaluation of toxicity and efficacy failure.

Methods commonly used for the assay of tacrolimus include high performance liquid chromatography with tandem mass spectrometric detection (HPLC/MS/MS) and immunoassays. Immunoassays may react with metabolites as well as parent compound. Therefore assay results obtained with immunoassays may have a positive bias relative to results of HPLC/MS. The bias may depend upon the specific assay and laboratory. Comparison of the concentrations in published literature to patient concentrations using the current assays must be made with detailed knowledge of the assay methods and biological matrices employed. Whole blood is the matrix of choice and specimens should be collected into tubes containing ethylene diamine tetraacetic acid (EDTA) anti-coagulant. Heparin anti-coagulation is not recommended because of the tendency to form clots on storage. Samples which are not analyzed immediately should be stored at room temperature or in a refrigerator and assayed within 7 days; see assay instructions for specifics. If samples are to be kept longer they should be deep frozen at -20° C. One study showed drug recovery >90% for samples stored at -20° C for 6 months, with reduced recovery observed after 6 months.

## 2.7 Preparation for Intravenous Product

Prograf injection must be diluted with 0.9% Sodium Chloride Injection or 5% Dextrose Injection to a concentration between 0.004 mg/mL and 0.02 mg/mL prior to use. Diluted infusion solution should be stored in glass or polyethylene containers and should be discarded after 24 hours. The diluted infusion solution should not be stored in a PVC container due to decreased stability and the potential for extraction of phthalates. In situations where more dilute solutions are utilized (e.g., pediatric dosing, etc.), PVC-free tubing should likewise be used to minimize the potential for significant drug adsorption onto the tubing.

Parenteral drug products should be inspected visually for particulate matter and discoloration prior to administration, whenever solution and container permit.

Due to the chemical instability of tacrolimus in alkaline media, Prograf injection should not be mixed or co-infused with solutions of pH 9 or greater (e.g., ganciclovir or acyclovir).

## 3 DOSAGE FORMS AND STRENGTHS

- Oblong, hard capsule for oral administration contains anhydrous tacrolimus USP as follows:
  - 0.5 mg, light-yellow color, imprinted in red “0.5 mg” on the capsule cap and “logo607”\* on capsule body
  - 1 mg, white color, imprinted in red “1 mg” on the capsule cap and “logo617”\* on capsule body
  - 5 mg, grayish-red color, imprinted with white “5 mg” on the capsule cap and “logo657”\* on capsule body

\*The logo is a letter ‘f’ in a box as shown on the capsules -- 

- 1 mL ampule for IV infusion contains anhydrous tacrolimus USP as follows:
  - 5 mg/mL, sterile solution

## 4 CONTRAINDICATIONS

Prograf is contraindicated in patients with a hypersensitivity to tacrolimus. Prograf injection is contraindicated in patients with a hypersensitivity to HCO-60 (polyoxyl 60 hydrogenated castor oil). Hypersensitivity symptoms reported include dyspnea, rash, pruritus, and acute respiratory distress syndrome [see *Adverse Reactions (6)*].

## 5 WARNINGS AND PRECAUTIONS

### 5.1 Management of Immunosuppression

Only physicians experienced in immunosuppressive therapy and management of organ transplant patients should use Prograf. Patients receiving the drug should be managed in facilities equipped and staffed with adequate laboratory and supportive medical resources. The physicians responsible for maintenance therapy should have complete information requisite for the follow up of the patient [see *Boxed Warning*].

### 5.2 Lymphoma and Other Malignancies

Patients receiving immunosuppressants, including Prograf, are at increased risk of developing lymphomas and other malignancies, particularly of the skin [see *Boxed Warning*]. The risk appears to be related to the intensity and duration of immunosuppression rather than to the use of any specific agent.

As usual for patients with increased risk for skin cancer, exposure to sunlight and UV light should be limited by wearing protective clothing and using a sunscreen with a high protection factor.

Post transplant lymphoproliferative disorder (PTLD) has been reported in immunosuppressed organ transplant recipients. The majority of PTLD events appear related to Epstein Barr Virus (EBV) infection. The risk of PTLD appears greatest in those individuals who are EBV seronegative, a population which includes many young children.

### **5.3 Serious Infections**

Patients receiving immunosuppressants, including Prograf, are at increased risk of developing bacterial, viral, fungal, and protozoal infections, including opportunistic infections [*see Boxed Warning and Warnings and Precautions (5.4, 5.5)*]. These infections may lead to serious, including fatal, outcomes. Because of the danger of oversuppression of the immune system which can increase susceptibility to infection, combination immunosuppressant therapy should be used with caution.

### **5.4 Polyoma Virus Infections**

Patients receiving immunosuppressants, including Prograf, are at increased risk for opportunistic infections, including polyoma virus infections. Polyoma virus infections in transplant patients may have serious, and sometimes fatal, outcomes. These include polyoma virus-associated nephropathy (PVAN), mostly due to BK virus infection, and JC virus-associated progressive multifocal leukoencephalopathy (PML) which have been observed in patients receiving tacrolimus [*see Adverse Reactions (6.2)*].

PVAN is associated with serious outcomes, including deteriorating renal function and kidney graft loss [*see Adverse Reactions (6.2)*]. Patient monitoring may help detect patients at risk for PVAN.

Cases of PML have been reported in patients treated with Prograf. PML, which is sometimes fatal, commonly presents with hemiparesis, apathy, confusion, cognitive deficiencies and ataxia. Risk factors for PML include treatment with immunosuppressant therapies and impairment of immune function. In immunosuppressed patients, physicians should consider PML in the differential diagnosis in patients reporting neurological symptoms and consultation with a neurologist should be considered as clinically indicated.

Reductions in immunosuppression should be considered for patients who develop evidence of PVAN or PML. Physicians should also consider the risk that reduced immunosuppression represents to the functioning allograft.

### **5.5 Cytomegalovirus (CMV) Infections**

Patients receiving immunosuppressants, including Prograf, are at increased risk of developing CMV viremia and CMV disease. The risk of CMV disease is highest among transplant recipients seronegative for CMV at time of transplant who receive a graft from a CMV seropositive donor. Therapeutic approaches to limiting CMV disease exist and should be routinely provided. Patient monitoring may help detect patients at risk for CMV disease. Consideration should be given to reducing the amount of immunosuppression in patients who develop CMV viremia and/or CMV disease.

### **5.6 New Onset Diabetes After Transplant**

Prograf was shown to cause new onset diabetes mellitus in clinical trials of kidney, liver, and heart transplantation. New onset diabetes after transplantation may be reversible in some patients. Black and Hispanic kidney transplant patients are at an increased risk. Blood glucose concentrations should be monitored closely in patients using Prograf [*see Adverse Reactions (6.1)*].



## 5.7 Nephrotoxicity

Prograf, like other calcineurin-inhibitors, can cause acute or chronic nephrotoxicity, particularly when used in high doses. Acute nephrotoxicity is most often related to vasoconstriction of the afferent renal arteriole, is characterized by increasing serum creatinine, hyperkalemia, and/or a decrease in urine output, and is typically reversible. Chronic calcineurin-inhibitor nephrotoxicity is associated with increased serum creatinine, decreased kidney graft life, and characteristic histologic changes observed on renal biopsy; the changes associated with chronic calcineurin-inhibitor nephrotoxicity are typically progressive. Patients with impaired renal function should be monitored closely as the dosage of Prograf may need to be reduced. In patients with persistent elevations of serum creatinine who are unresponsive to dosage adjustments, consideration should be given to changing to another immunosuppressive therapy.

Based on reported adverse reactions terms related to decreased renal function, nephrotoxicity was reported in approximately 52% of kidney transplantation patients and in 40% and 36% of liver transplantation patients receiving Prograf in the U.S. and European randomized trials, respectively, and in 59% of heart transplantation patients in a European randomized trial [*see Adverse Reactions (6.1)*].

Due to the potential for additive or synergistic impairment of renal function, care should be taken when administering Prograf with drugs that may be associated with renal dysfunction. These include, but are not limited to, aminoglycosides, ganciclovir, amphotericin B, cisplatin, nucleotide reverse transcriptase inhibitors (e.g., tenofovir) and protease inhibitors (e.g., ritonavir, indinavir). Similarly, care should be exercised when administering with CYP3A4 inhibitors such as antifungal drugs (e.g., ketoconazole), calcium channel blockers (e.g., diltiazem, verapamil), and macrolide antibiotics (e.g., clarithromycin, erythromycin, troleandomycin) which will result in increased tacrolimus whole blood concentrations due to inhibition of tacrolimus metabolism [*see Drug Interactions (7.3, 7.4, 7.5, 7.6)*].

## 5.8 Neurotoxicity

Prograf may cause a spectrum of neurotoxicities, particularly when used in high doses. The most severe neurotoxicities include posterior reversible encephalopathy syndrome (PRES), delirium, and coma. Patients treated with tacrolimus have been reported to develop PRES. Symptoms indicating PRES include headache, altered mental status, seizures, visual disturbances and hypertension. Diagnosis may be confirmed by radiological procedure. If PRES is suspected or diagnosed, blood pressure control should be maintained and immediate reduction of immunosuppression is advised. This syndrome is characterized by reversal of symptoms upon reduction or discontinuation of immunosuppression.

Coma and delirium, in the absence of PRES, have also been associated with high plasma concentrations of tacrolimus. Seizures have occurred in adult and pediatric patients receiving Prograf [*see Adverse Reactions (6.1)*].

Less severe neurotoxicities, include tremors, paresthesias, headache, and other changes in motor function, mental status, and sensory function [*see Adverse Reactions (6.1)*]. Tremor and headache have been associated with high whole-blood concentrations of tacrolimus and may respond to dosage adjustment.

## 5.9 Hyperkalemia

Hyperkalemia has been reported with Prograf use. Serum potassium levels should be monitored. Careful consideration should be given prior to use of other agents also associated with hyperkalemia (e.g., potassium-sparing diuretics, ACE inhibitors, angiotensin receptor blockers) during Prograf therapy [*see Adverse Reactions (6.1)*].

## 5.10 Hypertension

Hypertension is a common adverse effect of Prograf therapy and may require antihypertensive therapy [*see Adverse Reactions (6.1)*]. The control of blood pressure can be accomplished with any of the common antihypertensive agents, though careful consideration should be given prior to use of antihypertensive agents associated with hyperkalemia (e.g., potassium-sparing diuretics, ACE inhibitors, angiotensin receptor blockers) [*see Warnings and Precautions (5.9)*]. Calcium-channel blocking agents may increase tacrolimus blood concentrations and therefore require dosage reduction of Prograf [*see Drug Interactions (7.5)*].

### 5.11 Anaphylactic Reactions with Prograf Injection

Anaphylactic reactions have occurred with injectables containing castor oil derivatives, including Prograf, in a small percentage of patients (0.6%). The exact cause of these reactions is not known. Prograf injection should be reserved for patients who are unable to take Prograf capsules [see *Indications and Usage (1.4)*].

Patients receiving Prograf injection should be under continuous observation for at least the first 30 minutes following the start of the infusion and at frequent intervals thereafter. If signs or symptoms of anaphylaxis occur, the infusion should be stopped. An aqueous solution of epinephrine should be available at the bedside as well as a source of oxygen.

### 5.12 Use with Sirolimus

The safety and efficacy of Prograf with sirolimus has not been established in kidney transplant patients.

Use of sirolimus with Prograf in studies of *de novo* liver transplant patients was associated with an excess mortality, graft loss, and hepatic artery thrombosis (HAT) and is not recommended [see *Indications and Usage (1.4)*].

Use of sirolimus (2 mg per day) with Prograf in heart transplant patients in a U.S. trial was associated with increased risk of renal function impairment, wound healing complications, and insulin-dependent post-transplant diabetes mellitus, and is not recommended [see *Clinical Studies (14.3)*].

### 5.13 Use with CYP3A4 Inhibitors and Inducers

When coadministering Prograf with strong CYP3A4-inhibitors (e.g., telaprevir, boceprevir, ritonavir, ketoconazole, itraconazole, voriconazole, clarithromycin) and strong inducers (e.g., rifampin, rifabutin) adjustments in the dosing regimen of Prograf and subsequent frequent monitoring of tacrolimus whole blood trough concentrations and tacrolimus-associated adverse reactions are recommended [see *Drug Interactions (7)*].

### 5.14 QT Prolongation

Prograf may prolong the QT/QTc interval and may cause Torsade de Pointes. Avoid Prograf in patients with congenital long QT syndrome. In patients with congestive heart failure, bradyarrhythmias, those taking certain antiarrhythmic medications or other medicinal products that lead to QT prolongation, and those with electrolyte disturbances such as hypokalemia, hypocalcemia, or hypomagnesemia, consider obtaining electrocardiograms and monitoring electrolytes (magnesium, potassium, calcium) periodically during treatment.

When coadministering Prograf with other substrates and/or inhibitors of CYP3A4 that also have the potential to prolong the QT interval, a reduction in Prograf dose, frequent monitoring of tacrolimus whole blood concentrations, and monitoring for QT prolongation is recommended. Use of Prograf with amiodarone has been reported to result in increased tacrolimus whole blood concentrations with or without concurrent QT prolongation [see *Drug Interactions (7)*].

### 5.15 Myocardial Hypertrophy

Myocardial hypertrophy has been reported in infants, children, and adults, particularly those with high tacrolimus trough concentrations, and is generally manifested by echocardiographically demonstrated concentric increases in left ventricular posterior wall and interventricular septum thickness. This condition appears reversible in most cases following dose reduction or discontinuance of therapy. In patients who develop renal failure or clinical manifestations of ventricular dysfunction while receiving Prograf therapy, echocardiographic evaluation should be considered. If myocardial hypertrophy is diagnosed, dosage reduction or discontinuation of Prograf should be considered [see *Adverse Reactions (6.2)*].

### 5.16 Immunizations

The use of live vaccines should be avoided during treatment with tacrolimus; examples include (not limited to) the following: intranasal influenza, measles, mumps, rubella, oral polio, BCG, yellow fever, varicella, and TY21a typhoid vaccines.

## 5.17 Pure Red Cell Aplasia

Cases of pure red cell aplasia (PRCA) have been reported in patients treated with tacrolimus. A mechanism for tacrolimus-induced PRCA has not been elucidated. All patients reported risk factors for PRCA such as parvovirus B19 infection, underlying disease, or concomitant medications associated with PRCA. If PRCA is diagnosed, discontinuation of Prograf should be considered [see *Adverse Reactions* (6.2)].

## 5.18 Gastrointestinal Perforation

Gastrointestinal perforation has been reported in patients treated with Prograf; all reported cases were considered to be a complication of transplant surgery or accompanied by infection, diverticulum, or malignant neoplasm. As gastrointestinal perforation may be serious or life-threatening, appropriate medical/surgical management should be instituted promptly [see *Adverse Reactions* (6.1)].

## 6 ADVERSE REACTIONS

The following serious and otherwise important adverse drug reactions are discussed in greater detail in other sections of labeling:

- Lymphoma and Other Malignancies [see *Boxed Warning, Warnings and Precautions* (5.2)]
- Serious Infections [see *Boxed Warning, Warnings and Precautions* (5.3)]
- Polyoma Virus Infections [see *Boxed Warning, Warnings and Precautions* (5.4)]
- CMV Infections [see *Boxed Warning, Warnings and Precautions* (5.5)]
- New Onset Diabetes After Transplant [see *Warnings and Precautions* (5.6)]
- Nephrotoxicity [see *Warnings and Precautions* (5.7)]
- Neurotoxicity [see *Warnings and Precautions* (5.8)]
- Hyperkalemia [see *Warnings and Precautions* (5.9)]
- Hypertension [see *Warnings and Precautions* (5.10)]
- Anaphylaxis with Prograf Injection [see *Warnings and Precautions* (5.11)]
- Myocardial Hypertrophy [see *Warnings and Precautions* (5.15)]
- Pure Red Cell Aplasia [see *Warnings and Precautions* (5.17)]
- Gastrointestinal Perforation [see *Warnings and Precautions* (5.18)]

### 6.1 Clinical Studies Experience

Because clinical trials are conducted under widely varying conditions, adverse reaction rates observed in the clinical trials of a drug cannot be directly compared to rates in the clinical trials of another drug and may not reflect the rates observed in practice. In addition, the clinical trials were not designed to establish comparative differences across study arms with regards to the adverse reactions discussed below.

#### *Kidney Transplant*

The incidence of adverse reactions was determined in three randomized kidney transplant trials. One of the trials used azathioprine (AZA) and corticosteroids and two of the trials used mycophenolate mofetil (MMF) and corticosteroids concomitantly for maintenance immunosuppression.

Prograf-based immunosuppression in conjunction with azathioprine and corticosteroids following kidney transplantation was assessed in trial where 205 patients received Prograf based immunosuppression and 207 patients received cyclosporine based immunosuppression. The trial population had a mean age of 43 years (mean±sd was 43±13 years on Prograf and 44±12 years on cyclosporine arm), the distribution was 61% male, and the composition was White (58%), Black (25%), Hispanic (12%) and Other (5%). The 12 month post-transplant information from this trial is presented below.

The most common adverse reactions ( $\geq 30\%$ ) observed in Prograf-treated kidney transplant patients are: infection, tremor, hypertension, abnormal renal function, constipation, diarrhea, headache, abdominal pain, insomnia, nausea, hypomagnesemia, urinary tract infection, hypophosphatemia, peripheral edema, asthenia, pain, hyperlipidemia, hyperkalemia and anemia.

Adverse reactions that occurred in  $\geq 15\%$  of kidney transplant patients treated with Prograf in conjunction with azathioprine are presented below:

**Table 4. Kidney Transplantation: Adverse Reactions Occurring in  $\geq 15\%$  of Patients Treated with Prograf in Conjunction with Azathioprine (AZA)**

|   | <b>Prograf/AZA<br/>(N=205)</b> | <b>Cyclosporine/AZA<br/>(N=207)</b> |
|---|--------------------------------|-------------------------------------|
| <b><u>Nervous System</u></b>            |                                |                                     |
| Tremor                                  | 54%                            | 34%                                 |
| Headache                                | 44%                            | 38%                                 |
| Insomnia                                | 32%                            | 30%                                 |
| Paresthesia                             | 23%                            | 16%                                 |
| Dizziness                               | 19%                            | 16%                                 |
| <b><u>Gastrointestinal</u></b>          |                                |                                     |
| Diarrhea                                | 44%                            | 41%                                 |
| Nausea                                  | 38%                            | 36%                                 |
| Constipation                            | 35%                            | 43%                                 |
| Vomiting                                | 29%                            | 23%                                 |
| Dyspepsia                               | 28%                            | 20%                                 |
| <b><u>Cardiovascular</u></b>            |                                |                                     |
| Hypertension                            | 50%                            | 52%                                 |
| Chest Pain                              | 19%                            | 13%                                 |
| <b><u>Urogenital</u></b>                |                                |                                     |
| Creatinine Increased                    | 45%                            | 42%                                 |
| Urinary Tract Infection                 | 34%                            | 35%                                 |
| <b><u>Metabolic and Nutritional</u></b> |                                |                                     |
| Hypophosphatemia                        | 49%                            | 53%                                 |
| Hypomagnesemia                          | 34%                            | 17%                                 |
| Hyperlipemia                            | 31%                            | 38%                                 |
| Hyperkalemia                            | 31%                            | 32%                                 |
| Diabetes Mellitus                       | 24%                            | 9%                                  |
| Hypokalemia                             | 22%                            | 25%                                 |
| Hyperglycemia                           | 22%                            | 16%                                 |
| Edema                                   | 18%                            | 19%                                 |

|                                   |     |     |
|-----------------------------------|-----|-----|
| <b><u>Hemic and Lymphatic</u></b> |     |     |
| Anemia                            | 30% | 24% |
| Leukopenia                        | 15% | 17% |
| <b><u>Miscellaneous</u></b>       |     |     |
| Infection                         | 45% | 49% |
| Peripheral Edema                  | 36% | 48% |
| Asthenia                          | 34% | 30% |
| Abdominal Pain                    | 33% | 31% |
| Pain                              | 32% | 30% |
| Fever                             | 29% | 29% |
| Back Pain                         | 24% | 20% |
| <b><u>Respiratory System</u></b>  |     |     |
| Dyspnea                           | 22% | 18% |
| Cough Increased                   | 18% | 15% |
| <b><u>Musculoskeletal</u></b>     |     |     |
| Arthralgia                        | 25% | 24% |
| <b><u>Skin</u></b>                |     |     |
| Rash                              | 17% | 12% |
| Pruritus                          | 15% | 7%  |

Two trials were conducted for Prograf-based immunosuppression in conjunction with MMF and corticosteroids. In the non-US trial (Study 1), the incidence of adverse reactions was based on 1195 kidney transplant patients that received Prograf (Group C, n=403), or one of two cyclosporine (CsA) regimens (Group A, n=384 and Group B, n=408) in combination with MMF and corticosteroids; all patients, except those in one of the two cyclosporine groups, also received induction with daclizumab. The trial population had a mean age of 46 years (range 17 to 76), the distribution was 65% male, and the composition was 93% Caucasian. The 12 month post-transplant information from this trial is presented below.

Adverse reactions that occurred in  $\geq 10\%$  of kidney transplant patients treated with Prograf in conjunction with MMF in Study 1 [Note: This trial was conducted entirely outside of the United States. Such trials often report a lower incidence of adverse reactions in comparison to U.S. trials] are presented below:

**Table 5. Kidney Transplantation: Adverse Reactions Occurring in  $\geq 10\%$  of Patients Treated with Prograf in Conjunction with MMF (Study 1)**

|                         | <b>Prograf<br/>(Group C)<br/>(N=403)</b> | <b>Cyclosporine<br/>(Group A)<br/>(N=384)</b> | <b>Cyclosporine<br/>(Group B)<br/>(N=408)</b> |
|-------------------------|--|---|---|
| Diarrhea                | 25%                                      | 16%   | 13%   |
| Urinary Tract Infection | 24%                                      | 28%   | 24%   |
| Anemia                  | 17%                                      | 19%   | 17%   |
| Hypertension            | 13%                                      | 14%   | 12%   |
| Leukopenia              | 13%                                      | 10%   | 10%   |
| Edema Peripheral        | 11%                                      | 12%   | 13%   |
| Hyperlipidemia          | 10%                                      | 15%   | 13%   |

Key: Group A = CsA/MMF/CS, B = CsA/MMF/CS/Daclizumab, C = Tac/MMF/CS/Daclizumab  
CsA = Cyclosporine, CS = Corticosteroids, Tac = Tacrolimus, MMF = mycophenolate mofetil

In the U.S. trial (Study 2) with Prograf-based immunosuppression in conjunction with MMF and corticosteroids, 424 kidney transplant patients received Prograf (n=212) or cyclosporine (n=212) in combination with MMF 1 gram twice daily, basiliximab induction, and corticosteroids. The trial population had a mean age of 48 years (range 17 to 77), the distribution was 63% male, and the composition was White (74%), Black (20%), Asian (3%) and other (3%). The 12 month post-transplant information from this trial is presented below.

Adverse reactions that occurred in  $\geq 15\%$  of kidney transplant patients treated with Prograf in conjunction with MMF in Study 2 are presented below:

**Table 6. Kidney Transplantation: Adverse Reactions Occurring in  $\geq 15\%$  of Patients Treated with Prograf in Conjunction with MMF (Study 2)**

|   | <b>Prograf/MMF<br/>(N=212)</b> | <b>Cyclosporine/MMF<br/>(N=212)</b> |
|---|--------------------------------|-------------------------------------|
| <b><u>Gastrointestinal Disorders</u></b>                      |                                |                                     |
| Diarrhea  | 44%                            | 26%                                 |
| Nausea  | 39%                            | 47%                                 |
| Constipation  | 36%                            | 41%                                 |
| Vomiting  | 26%                            | 25%                                 |
| Dyspepsia   | 18%                            | 15%                                 |
| <b><u>Injury, Poisoning, and Procedural Complications</u></b> |                                |                                     |
| Post-Procedural Pain  | 29%                            | 27%                                 |
| Incision Site Complication                                    | 28%                            | 23%                                 |
| Graft Dysfunction   | 24%                            | 18%                                 |
| <b><u>Metabolism and Nutrition Disorders</u></b>              |                                |                                     |
| Hypomagnesemia  | 28%                            | 22%                                 |
| Hypophosphatemia  | 28%                            | 21%                                 |
| Hyperkalemia  | 26%                            | 19%                                 |
| Hyperglycemia   | 21%                            | 15%                                 |
| Hyperlipidemia  | 18%                            | 25%                                 |
| Hypokalemia   | 16%                            | 18%                                 |
| <b><u>Nervous System Disorders</u></b>                        |                                |                                     |
| Tremor  | 34%                            | 20%                                 |
| Headache  | 24%                            | 25%                                 |
| <b><u>Blood and Lymphatic System Disorders</u></b>            |                                |                                     |
| Anemia  | 30%                            | 28%                                 |
| Leukopenia  | 16%                            | 12%                                 |

| <b><u>Miscellaneous</u></b> |     |     |
|-----------------------------|-----|-----|
| Edema Peripheral            | 35% | 46% |
| Hypertension                | 32% | 35% |
| Insomnia                    | 30% | 21% |
| Urinary Tract Infection     | 26% | 22% |
| Blood Creatinine Increased  | 23% | 23% |

Less frequently observed adverse reactions in both liver transplantation and kidney transplantation patients are described under the subsection *Less Frequently Reported Adverse Reactions*.

#### *Liver Transplantation*

There were two randomized comparative liver transplant trials. In the U.S. trial, 263 adult and pediatric patients received tacrolimus and steroids and 266 patients received cyclosporine-based immunosuppressive regimen (CsA/AZA). The trial population had a mean age of 44 years (range 0.4 to 70), the distribution was 52% male, and the composition was White (78%), Black (5%), Asian (2%), Hispanic (13%) and Other (2%). In the European trial, 270 patients received tacrolimus and steroids and 275 patients received CsA/AZA. The trial population had a mean age of 46 years (range 15 to 68), the distribution was 59% male, and the composition was White (95.4%), Black (1%), Asian (2%) and Other (2%).

The proportion of patients reporting more than one adverse event was > 99% in both the tacrolimus group and the CsA/AZA group. Precautions must be taken when comparing the incidence of adverse reactions in the U.S. trial to that in the European trial. The 12-month post-transplant information from the U.S. trial and from the European trial is presented below. The two trials also included different patient populations and patients were treated with immunosuppressive regimens of differing intensities. Adverse reactions reported in  $\geq 15\%$  in tacrolimus patients (combined trial results) are presented below for the two controlled trials in liver transplantation.

The most common adverse reactions ( $\geq 40\%$ ) observed in Prograf-treated liver transplant patients are: tremor, headache, diarrhea, hypertension, nausea, abnormal renal function, abdominal pain, insomnia, paresthesia, anemia, pain, fever, asthenia, hyperkalemia, hypomagnesemia, and hyperglycemia. These all occur with oral and IV administration of Prograf and some may respond to a reduction in dosing (e.g., tremor, headache, paresthesia, hypertension). Diarrhea was sometimes associated with other gastrointestinal complaints such as nausea and vomiting.

**Table 7. Liver Transplantation: Adverse Reactions Occurring in  $\geq 15\%$  of Patients Treated with Prograf**

|                                | U.S. TRIAL         |                                 | EUROPEAN TRIAL     |                                 |
|--------------------------------|--------------------|---------------------------------|--------------------|---------------------------------|
|                                | Prograf<br>(N=250) | Cyclosporine/<br>AZA<br>(N=250) | Prograf<br>(N=264) | Cyclosporine/<br>AZA<br>(N=265) |
| <b><u>Nervous System</u></b>   |                    |                                 |                    |                                 |
| Headache                       | 64%                | 60%                             | 37%                | 26%                             |
| Insomnia                       | 64%                | 68%                             | 32%                | 23%                             |
| Tremor                         | 56%                | 46%                             | 48%                | 32%                             |
| Paresthesia                    | 40%                | 30%                             | 17%                | 17%                             |
| <b><u>Gastrointestinal</u></b> |                    |                                 |                    |                                 |
| Diarrhea                       | 72%                | 47%                             | 37%                | 27%                             |
| Nausea                         | 46%                | 37%                             | 32%                | 27%                             |
| LFT Abnormal                   | 36%                | 30%                             | 6%                 | 5%                              |
| Anorexia                       | 34%                | 24%                             | 7%                 | 5%                              |
| Vomiting                       | 27%                | 15%                             | 14%                | 11%                             |
| Constipation                   | 24%                | 27%                             | 23%                | 21%                             |

**Cardiovascular**

|              |     |     |     |     |
|--------------|-----|-----|-----|-----|
| Hypertension | 47% | 56% | 38% | 43% |
|--------------|-----|-----|-----|-----|

**Urogenital**

|                          |     |     |     |     |
|--------------------------|-----|-----|-----|-----|
| Kidney Function Abnormal | 40% | 27% | 36% | 23% |
| Creatinine Increased     | 39% | 25% | 24% | 19% |
| BUN Increased            | 30% | 22% | 12% | 9%  |
| Oliguria                 | 18% | 15% | 19% | 12% |
| Urinary Tract Infection  | 16% | 18% | 21% | 19% |

**Metabolic and Nutritional**

|                |     |     |     |     |
|----------------|-----|-----|-----|-----|
| Hypomagnesemia | 48% | 45% | 16% | 9%  |
| Hyperglycemia  | 47% | 38% | 33% | 22% |
| Hyperkalemia   | 45% | 26% | 13% | 9%  |
| Hypokalemia    | 29% | 34% | 13% | 16% |

**Hemic and Lymphatic**

|                  |     |     |     |     |
|------------------|-----|-----|-----|-----|
| Anemia           | 47% | 38% | 5%  | 1%  |
| Leukocytosis     | 32% | 26% | 8%  | 8%  |
| Thrombocytopenia | 24% | 20% | 14% | 19% |

**Miscellaneous**

|                  |     |     |     |     |
|------------------|-----|-----|-----|-----|
| Pain             | 63% | 57% | 24% | 22% |
| Abdominal Pain   | 59% | 54% | 29% | 22% |
| Asthenia         | 52% | 48% | 11% | 7%  |
| Fever            | 48% | 56% | 19% | 22% |
| Back Pain        | 30% | 29% | 17% | 17% |
| Ascites          | 27% | 22% | 7%  | 8%  |
| Peripheral Edema | 26% | 26% | 12% | 14% |

**Respiratory System**

|                  |     |     |     |     |
|------------------|-----|-----|-----|-----|
| Pleural Effusion | 30% | 32% | 36% | 35% |
| Dyspnea          | 29% | 23% | 5%  | 4%  |
| Atelectasis      | 28% | 30% | 5%  | 4%  |

**Skin and Appendages**

|          |     |     |     |    |
|----------|-----|-----|-----|----|
| Pruritus | 36% | 20% | 15% | 7% |
| Rash     | 24% | 19% | 10% | 4% |



Less frequently observed adverse reactions in both liver transplantation and kidney transplantation patients are described under the subsection *Less Frequently Reported Adverse Reactions*.

#### *Heart Transplantation*

The incidence of adverse reactions was determined based on two trials in primary orthotopic heart transplantation. In a trial conducted in Europe, 314 patients received a regimen of antibody induction, corticosteroids and azathioprine (AZA) in combination with Prograf (n=157) or cyclosporine (n=157) for 18 months. The trial population had a mean age of 51 years (range 18 to 65), the distribution was 82% male, and the composition was White (96%), Black (3%) and other (1%).

The most common adverse reactions ( $\geq 15\%$ ) observed in Prograf-treated heart transplant patients are: abnormal renal function, hypertension, diabetes mellitus, CMV infection, tremor, hyperglycemia, leukopenia, infection, anemia, bronchitis, pericardial effusion, urinary tract infection and hyperlipemia.

Adverse reactions in heart transplant patients in the European trial are presented below:

**Table 8. Heart Transplantation: Adverse Reactions Occurring in  $\geq 15\%$  of Patients Treated with Prograf in Conjunction with Azathioprine (AZA)**

|  | <b>Prograf/AZA<br/>(n=157)</b> | <b>Cyclosporine/AZA<br/>(n=157)</b> |
|--|--------------------------------|-------------------------------------|
| <b>Cardiovascular System</b>               |                                |                                     |
| Hypertension                               | 62%                            | 69%                                 |
| Pericardial Effusion                       | 15%                            | 14%                                 |
| <b>Body as a Whole</b>                     |                                |                                     |
| CMV Infection                              | 32%                            | 30%                                 |
| Infection                                  | 24%                            | 21%                                 |
| <b>Metabolic and Nutritional Disorders</b> |                                |                                     |
| Diabetes Mellitus                          | 26%                            | 16%                                 |
| Hyperglycemia                              | 23%                            | 17%                                 |
| Hyperlipemia                               | 18%                            | 27%                                 |
| <b>Hemic and Lymphatic System</b>          |                                |                                     |
| Anemia                                     | 50%                            | 36%                                 |
| Leukopenia                                 | 48%                            | 39%                                 |
| <b>Urogenital System</b>                   |                                |                                     |
| Kidney Function Abnormal                   | 56%                            | 57%                                 |
| Urinary Tract Infection                    | 16%                            | 12%                                 |
| <b>Respiratory System</b>                  |                                |                                     |
| Bronchitis                                 | 17%                            | 18%                                 |
| <b>Nervous System</b>                      |                                |                                     |
| Tremor                                     | 15%                            | 6%                                  |

In the European trial, the cyclosporine trough concentrations were above the pre-defined target range (i.e., 100 to 200 ng/mL) at Day 122 and beyond in 32 to 68% of the patients in the cyclosporine treatment arm, whereas the tacrolimus trough concentrations were within the pre-defined target range (i.e., 5 to 15 ng/mL) in 74 to 86% of the patients in the tacrolimus treatment arm.

In a U.S. trial, the incidence of adverse reactions was based on 331 heart transplant patients that received corticosteroids and Prograf in combination with sirolimus (n=109), Prograf in combination with MMF (n=107) or cyclosporine modified in combination with MMF (n=115) for 1 year. The trial population had a mean age of 53 years (range 18 to 75), the distribution was 78% male, and the composition was White (83%), Black (13%) and other (4%).

Only selected targeted treatment-emergent adverse reactions were collected in the U.S. heart transplantation trial. Those reactions that were reported at a rate of 15% or greater in patients treated with Prograf and MMF include the following: any target adverse reactions (99%), hypertension (89%), hyperglycemia requiring antihyperglycemic therapy (70%), hypertriglyceridemia (65%), anemia (hemoglobin <10.0 g/dL) (65%), fasting blood glucose >140 mg/dL (on two separate occasions) (61%), hypercholesterolemia (57%), hyperlipidemia (34%), WBCs <3000 cells/mcL (34%), serious bacterial infections (30%), magnesium <1.2 mEq/L (24%), platelet count <75,000 cells/mcL (19%), and other opportunistic infections (15%).

Other targeted treatment-emergent adverse reactions in Prograf-treated patients occurred at a rate of less than 15%, and include the following: Cushingoid features, impaired wound healing, hyperkalemia, *Candida* infection, and CMV infection/syndrome.

### New Onset Diabetes After Transplant

#### *Kidney Transplant*

New Onset Diabetes After Transplant (NODAT) is defined as a composite of fasting plasma glucose  $\geq 126$  mg/dL, HbA<sub>1c</sub>  $\geq 6\%$ , insulin use  $\geq 30$  days or oral hypoglycemic use. In a trial in kidney transplant patients (Study 2), NODAT was observed in 75% in the Prograf-treated and 61% in the Neoral-treated patients without pre-transplant history of diabetes mellitus (Table 9) [see *Clinical Studies (14.1)*].

**Table 9. Incidence of New Onset Diabetes After Transplant at 1 year in Kidney Transplant Recipients in a Phase 3 Trial (Study 2)**

| Parameter                               | Treatment Group          |                         |
|---|--------------------------|-------------------------|
|   | Prograf/MMF<br>(n = 212) | Neoral/MMF<br>(n = 212) |
| NODAT                                   | 112/150 (75%)            | 93/152 (61%)            |
| Fasting Plasma Glucose $\geq 126$ mg/dL | 96/150 (64%)             | 80/152 (53%)            |
| HbA <sub>1c</sub> $\geq 6\%$            | 59/150 (39%)             | 28/152 (18%)            |
| Insulin Use $\geq 30$ days              | 9/150 (6%)               | 4/152 (3%)              |
| Oral Hypoglycemic Use                   | 15/150 (10%)             | 5/152 (3%)              |

In early trials of Prograf, Post-Transplant Diabetes Mellitus (PTDM) was evaluated with a more limited criteria of “use of insulin for 30 or more consecutive days with < 5 day gap” in patients without a prior history of insulin-dependent diabetes mellitus or non-insulin dependent diabetes mellitus. Data are presented in Tables 10 to 13. PTDM was reported in 20% of Prograf/Azathioprine (AZA)-treated kidney transplant patients without pre-transplant history of diabetes mellitus in a Phase 3 trial (Table 10). The median time to onset of PTDM was 68 days. Insulin dependence was reversible in 15% of these PTDM patients at one year and in 50% at 2 years post-transplant. Black and Hispanic kidney transplant patients were at an increased risk of development of PTDM (Table 11).

**Table 10. Incidence of Post-Transplant Diabetes Mellitus and Insulin Use at 2 Years in Kidney Transplant Recipients in a Phase 3 Trial using Azathioprine (AZA)**

| Status of PTDM <sup>a</sup>  | Prograf/AZA  | CsA/AZA    |
|--|--------------|------------|
| Patients without pre-transplant history of diabetes mellitus                   | 151          | 151        |
| New onset PTDM <sup>a</sup> , 1 <sup>st</sup> Year                             | 30/151 (20%) | 6/151 (4%) |
| Still insulin-dependent at one year in those without prior history of diabetes | 25/151 (17%) | 5/151 (3%) |
| New onset PTDM <sup>a</sup> post 1 year  | 1            | 0          |
| Patients with PTDM <sup>a</sup> at 2 years                                     | 16/151 (11%) | 5/151 (3%) |

<sup>a)</sup> Use of insulin for 30 or more consecutive days, with < 5 day gap, without a prior history of insulin-dependent diabetes mellitus or non-insulin dependent diabetes mellitus.

**Table 11. Development of Post-Transplant Diabetes Mellitus by Race or Ethnicity and by Treatment Group During First Year Post Kidney Transplantation in a Phase 3 Trial**

| Patient Race | Patients Who Developed PTDM <sup>a</sup> |              |
|--------------|--|--------------|
|              | Prograf                                  | Cyclosporine |
| Black        | 15/41 (37%)                              | 3 (8%)       |
| Hispanic     | 5/17 (29%)                               | 1 (6%)       |
| Caucasian    | 10/82 (12%)                              | 1 (1%)       |
| Other        | 0/11 (0%)                                | 1 (10%)      |
| Total        | 30/151 (20%)                             | 6 (4%)       |

<sup>a)</sup> Use of insulin for 30 or more consecutive days, with < 5 day gap, without a prior history of insulin-dependent diabetes mellitus or non-insulin dependent diabetes mellitus.

#### Liver Transplant

Insulin-dependent PTDM was reported in 18% and 11% of Prograf-treated liver transplant patients and was reversible in 45% and 31% of these patients at 1 year post-transplant, in the U.S. and European randomized trials, respectively, (Table 12). Hyperglycemia was associated with the use of Prograf in 47% and 33% of liver transplant recipients in the U.S. and European randomized trials, respectively, and may require treatment [see Adverse Reactions (6.1)].

**Table 12. Incidence of Post-Transplant Diabetes Mellitus and Insulin Use at 1 Year in Liver Transplant Recipients**

| Status of PTDM <sup>a</sup>         | US Trial |              | European Trial |              |
|-------------------------------------|----------|--------------|----------------|--------------|
|                                     | Prograf  | Cyclosporine | Prograf        | Cyclosporine |
| Patients at risk <sup>b</sup>       | 239      | 236          | 239            | 249          |
| New Onset PTDM <sup>a</sup>         | 42 (18%) | 30 (13%)     | 26 (11%)       | 12 (5%)      |
| Patients still on insulin at 1 year | 23 (10%) | 19 (8%)      | 18 (8%)        | 6 (2%)       |

<sup>a)</sup> Use of insulin for 30 or more consecutive days, with < 5 day gap, without a prior history of insulin-dependent diabetes mellitus or non-insulin dependent diabetes mellitus.

<sup>b)</sup> Patients without pre-transplant history of diabetes mellitus.

#### Heart Transplant

Insulin-dependent PTDM was reported in 13% and 22% of Prograf-treated heart transplant patients receiving mycophenolate mofetil (MMF) or azathioprine (AZA) and was reversible in 30% and 17% of these patients at one year post-transplant, in the U.S. and European randomized trials, respectively (Table 13). Hyperglycemia defined as two fasting plasma glucose levels  $\geq 126$  mg/dL was reported with the use of Prograf plus MMF or AZA in 32% and 35% of heart transplant recipients in the U.S. and European randomized trials, respectively, and may require treatment [see Adverse Reactions (6.1)].

**Table 13. Incidence of Post-Transplant Diabetes Mellitus and Insulin Use at 1 Year in Heart Transplant Recipients**

| Status of PTDM <sup>a</sup>                      | US Trial    |                  | European Trial |                  |
|--|-------------|------------------|----------------|------------------|
|  | Prograf/MMF | Cyclosporine/MMF | Prograf/AZA    | Cyclosporine/AZA |
| Patients at risk <sup>b</sup>                    | 75          | 83               | 132            | 138              |
| New Onset PTDM <sup>a</sup>                      | 10 (13%)    | 6 (7%)           | 29 (22%)       | 5 (4%)           |
| Patients still on insulin at 1 year <sup>c</sup> | 7 (9%)      | 1 (1%)           | 24 (18%)       | 4 (3%)           |

a) Use of insulin for 30 or more consecutive days without a prior history of insulin-dependent diabetes mellitus or non-insulin dependent diabetes mellitus.

b) Patients without pre-transplant history of diabetes mellitus.

c) 7-12 months for the U.S. trial.

*Less Frequently Reported Adverse Reactions (>3% and <15%)*

The following adverse reactions were reported in either liver, kidney, and/or heart transplant recipients who were treated with tacrolimus in clinical trials.

Nervous System [see Warnings and Precautions (5.8)]

Abnormal dreams, agitation, amnesia, anxiety, confusion, convulsion, crying, depression, elevated mood, emotional lability, encephalopathy, haemorrhagic stroke, hallucinations, hypertonia, incoordination, monoparesis, myoclonus, nerve compression, nervousness, neuralgia, neuropathy, paralysis flaccid, psychomotor skills impaired, psychosis, quadriparesis, somnolence, thinking abnormal, vertigo, writing impaired

Special Senses

Abnormal vision, amblyopia, ear pain, otitis media, tinnitus

Gastrointestinal

Cholangitis, cholestatic jaundice, duodenitis, dysphagia, esophagitis, flatulence, gastritis, gastroesophagitis, gastrointestinal hemorrhage, GGT increase, GI disorder, GI perforation, hepatitis, hepatitis granulomatous, ileus, increased appetite, jaundice, liver damage, oesophagitis ulcerative, oral moniliasis, pancreatic pseudocyst, rectal disorder, stomatitis

Cardiovascular

Abnormal ECG, angina pectoris, arrhythmia, atrial fibrillation, atrial flutter, bradycardia, cardiac fibrillation, cardiopulmonary failure, cardiovascular disorder, congestive heart failure, deep thrombophlebitis, echocardiogram abnormal, electrocardiogram QRS complex abnormal, electrocardiogram ST segment abnormal, heart failure, heart rate decreased, hemorrhage, hypotension, peripheral vascular disorder, phlebitis, postural hypotension, syncope, tachycardia, thrombosis, vasodilatation

Urogenital

Acute kidney failure [see Warnings and Precautions (5.7)], albuminuria, BK nephropathy, bladder spasm, cystitis, dysuria, hematuria, hydronephrosis, kidney failure, kidney tubular necrosis, nocturia, pyuria, toxic nephropathy, urge incontinence, urinary frequency, urinary incontinence, urinary retention, vaginitis

### Metabolic/Nutritional

Acidosis, alkaline phosphatase increased, alkalosis, ALT (SGPT) increased, AST (SGOT) increased, bicarbonate decreased, bilirubinemia, dehydration, GGT increased, gout, healing abnormal, hypercalcemia, hypercholesterolemia, hyperphosphatemia, hyperuricemia, hypervolemia, hypocalcemia, hypoglycemia, hyponatremia, hypoproteinemia, lactic dehydrogenase increase, weight gain

### Endocrine

Cushing's syndrome

### Hemic/Lymphatic

Coagulation disorder, ecchymosis, haematocrit increased, haemoglobin abnormal, hypochromic anemia, leukocytosis, polycythemia, prothrombin decreased, serum iron decreased

### Miscellaneous

Abdomen enlarged, abscess, accidental injury, allergic reaction, cellulitis, chills, fall, feeling abnormal, flu syndrome, generalized edema, hernia, mobility decreased, peritonitis, photosensitivity reaction, sepsis, temperature intolerance, ulcer

### Musculoskeletal

Arthralgia, cramps, generalized spasm, joint disorder, leg cramps, myalgia, myasthenia, osteoporosis

### Respiratory

Asthma, emphysema, hiccups, lung disorder, lung function decreased, pharyngitis, pneumonia, pneumothorax, pulmonary edema, respiratory disorder, rhinitis, sinusitis, voice alteration

### Skin

Acne, alopecia, exfoliative dermatitis, fungal dermatitis, herpes simplex, herpes zoster, hirsutism, neoplasm skin benign, skin discoloration, skin disorder, skin ulcer, sweating

## **6.2 Postmarketing Adverse Reactions**

The following adverse reactions have been reported from worldwide marketing experience with Prograf. Because these reactions are reported voluntarily from a population of uncertain size it is not always possible to reliably estimate their frequency or establish a causal relationship to drug exposure. Decisions to include these reactions in labeling are typically based on one or more of the following factors: (1) seriousness of the reaction, (2) frequency of the reporting, or (3) strength of causal connection to the drug.

Other reactions include:

#### *Cardiovascular*

Atrial fibrillation, atrial flutter, cardiac arrhythmia, cardiac arrest, electrocardiogram T wave abnormal, flushing, myocardial infarction, myocardial ischaemia, pericardial effusion, QT prolongation, Torsade de Pointes, venous thrombosis deep limb, ventricular extrasystoles, ventricular fibrillation, myocardial hypertrophy [*see Warnings and Precautions (5.15)*].

#### *Gastrointestinal*

Bile duct stenosis, colitis, enterocolitis, gastroenteritis, gastroesophageal reflux disease, hepatic cytolysis, hepatic necrosis, hepatotoxicity, impaired gastric emptying, liver fatty, mouth ulceration, pancreatitis haemorrhagic, pancreatitis necrotizing, stomach ulcer, venoocclusive liver disease

### *Hemic/Lymphatic*

Agranulocytosis, disseminated intravascular coagulation, hemolytic anemia, neutropenia, pancytopenia, thrombocytopenic purpura, thrombotic thrombocytopenic purpura, pure red cell aplasia [see *Warnings and Precautions (5.17)*]

### *Infections*

Cases of progressive multifocal leukoencephalopathy (PML), sometimes fatal; -polyoma virus-associated nephropathy, (PVAN) including graft loss [see *Warnings and Precautions (5.4)*]

### *Metabolic/Nutritional*

Glycosuria, increased amylase including pancreatitis, weight decreased

### *Miscellaneous*

Feeling hot and cold, feeling jittery, hot flushes, multi-organ failure, primary graft dysfunction

### *Nervous System*

Carpal tunnel syndrome, cerebral infarction, hemiparesis, leukoencephalopathy, mental disorder, mutism, posterior reversible encephalopathy syndrome (PRES) [see *Warnings and Precautions (5.8)*], progressive multifocal leukoencephalopathy (PML) [see *Warnings and Precautions (5.4)*], quadriplegia, speech disorder, syncope

### *Respiratory*

Acute respiratory distress syndrome, interstitial lung disease, lung infiltration, respiratory distress, respiratory failure

### *Skin*

Stevens-Johnson syndrome, toxic epidermal necrolysis

### *Special Senses*

Blindness, blindness cortical, hearing loss including deafness, photophobia

### *Urogenital*

Acute renal failure, cystitis haemorrhagic, hemolytic-uremic syndrome, micturition disorder

## **7 DRUG INTERACTIONS**

Since tacrolimus is metabolized mainly by CYP3A enzymes, drugs or substances known to inhibit these enzymes may increase tacrolimus whole blood concentrations. Drugs known to induce CYP3A enzymes may decrease tacrolimus whole blood concentrations [see *Warnings and Precautions (5.13)* and *Clinical Pharmacology (12.3)*]. Dose adjustments may be needed along with frequent monitoring of tacrolimus whole blood trough concentrations when Prograf is administered with CYP3A inhibitors or inducers. In addition, patients should be monitored for adverse reactions including changes in renal function and QT prolongation [see *Warnings and Precautions (5.7)* and *(5.14)*].

### **7.1 Mycophenolic Acid Products**

With a given dose of mycophenolic acid (MPA) products, exposure to MPA is higher with Prograf co-administration than with cyclosporine co-administration because cyclosporine interrupts the enterohepatic recirculation of MPA while tacrolimus does not. Clinicians should be aware that there is also a potential for increased MPA exposure after crossover from cyclosporine to Prograf in patients concomitantly receiving MPA-containing products.

## 7.2 Grapefruit Juice

Grapefruit juice inhibits CYP3A-enzymes resulting in increased tacrolimus whole blood trough concentrations, and patients should avoid eating grapefruit or drinking grapefruit juice with tacrolimus [see *Dosage and Administration (2.5)*].

## 7.3 Protease Inhibitors

Most protease inhibitors inhibit CYP3A enzymes and may increase tacrolimus whole blood concentrations. It is recommended to avoid concomitant use of tacrolimus with nelfinavir unless the benefits outweigh the risks [see *Clinical Pharmacology (12.3)*]. Whole blood concentrations of tacrolimus are markedly increased when co-administered with telaprevir or with boceprevir [see *Clinical Pharmacology (12.3)*]. Monitoring of tacrolimus whole blood concentrations and tacrolimus-associated adverse reactions, and appropriate adjustments in the dosing regimen of tacrolimus are recommended when tacrolimus and protease inhibitors (e.g., ritonavir, telaprevir, boceprevir) are used concomitantly.

## 7.4 Antifungal Agents

Frequent monitoring of whole blood concentrations and appropriate dosage adjustments of tacrolimus are recommended when concomitant use of the following antifungal drugs with tacrolimus is initiated or discontinued [see *Clinical Pharmacology (12.3)*].

Azoles: Voriconazole, posaconazole, itraconazole, ketoconazole, fluconazole and clotrimazole inhibit CYP3A metabolism of tacrolimus and increase tacrolimus whole blood concentrations. When initiating therapy with voriconazole or posaconazole in patients already receiving tacrolimus, it is recommended that the tacrolimus dose be initially reduced to one-third of the original dose and the subsequent tacrolimus doses be adjusted based on the tacrolimus whole blood concentrations.

Caspofungin is an inducer of CYP3A and decreases whole blood concentrations of tacrolimus.

## 7.5 Calcium Channel Blockers

Verapamil, diltiazem, nifedipine, and nicardipine inhibit CYP3A metabolism of tacrolimus and may increase tacrolimus whole blood concentrations. Monitoring of whole blood concentrations and appropriate dosage adjustments of tacrolimus are recommended when these calcium channel blocking drugs and tacrolimus are used concomitantly.

## 7.6 Antibacterials

Erythromycin, clarithromycin, troleandomycin and chloramphenicol inhibit CYP3A metabolism of tacrolimus and may increase tacrolimus whole blood concentrations. Monitoring of blood concentrations and appropriate dosage adjustments of tacrolimus are recommended when these drugs and tacrolimus are used concomitantly.

## 7.7 Antimycobacterials

Rifampin [see *Clinical Pharmacology (12.3)*] and rifabutin are inducers of CYP3A enzymes and may decrease tacrolimus whole blood concentrations. Monitoring of whole blood concentrations and appropriate dosage adjustments of tacrolimus are recommended when these antimycobacterial drugs and tacrolimus are used concomitantly.

## 7.8 Anticonvulsants

Phenytoin, carbamazepine and phenobarbital induce CYP3A enzymes and may decrease tacrolimus whole blood concentrations. Monitoring of whole blood concentrations and appropriate dosage adjustments of tacrolimus are recommended when these drugs and tacrolimus are used concomitantly.

Concomitant administration of phenytoin with tacrolimus may also increase phenytoin plasma concentrations. Thus, frequent monitoring phenytoin plasma concentrations and adjusting the phenytoin dose as needed are recommended when tacrolimus and phenytoin are administered concomitantly.

## 7.9 St. John's Wort (*Hypericum perforatum*)

St. John's Wort induces CYP3A enzymes and may decrease tacrolimus whole blood concentrations. Monitoring of whole blood concentrations and appropriate dosage adjustments of tacrolimus are recommended when St. John's Wort and tacrolimus are co-administered.

## 7.10 Gastric Acid Suppressors/Neutralizers

Lansoprazole and omeprazole, as CYP2C19 and CYP3A4 substrates, may potentially inhibit the CYP3A4 metabolism of tacrolimus and thereby substantially increase tacrolimus whole blood concentrations, especially in transplant patients who are intermediate or poor CYP2C19 metabolizers, as compared to those patients who are efficient CYP2C19 metabolizers. Cimetidine may also inhibit the CYP3A4 metabolism of tacrolimus and thereby substantially increase tacrolimus whole blood concentrations.

Coadministration with magnesium and aluminum hydroxide antacids increase tacrolimus whole blood concentrations [see *Clinical Pharmacology (12.3)*]. Monitoring of whole blood concentrations and appropriate dosage adjustments of tacrolimus are recommended when these drugs and tacrolimus are used concomitantly.

## 7.11 Others

Bromocriptine, nefazodone, metoclopramide, danazol, ethinyl estradiol, amiodarone, methylprednisolone, and herbal products containing schisandra sphenanthera extracts may inhibit CYP3A metabolism of tacrolimus and increase tacrolimus whole blood concentrations. Monitoring of blood concentrations and appropriate dosage adjustments of tacrolimus are recommended when these drugs and tacrolimus are co-administered.

# 8 USE IN SPECIFIC POPULATIONS

## 8.1 Pregnancy

Pregnancy Category C - There are no adequate and well-controlled studies in pregnant women. Tacrolimus is transferred across the placenta. The use of tacrolimus during pregnancy in humans has been associated with neonatal hyperkalemia and renal dysfunction. Tacrolimus given orally to pregnant rabbits at 0.5 to 4.3 times the clinical dose and pregnant rats at 0.8 to 6.9 times the clinical dose was associated with an increased incidence of fetal death *in utero*, fetal malformations (cardiovascular, skeletal, omphalocele, and gallbladder agenesis) and maternal toxicity. Prograf should be used during pregnancy only if the potential benefit to the mother justifies the potential risk to the fetus.

In pregnant rabbits, tacrolimus at oral doses of 0.32 and 1.0 mg/kg, 0.5 to 4.3 times the clinical dose range (0.075 – 0.2 mg/kg) based on body surface area, was associated with maternal toxicity as well as an increased incidence of abortions. At the 1 mg/kg dose, fetal rabbits showed an increased incidence of malformations (ventricular hypoplasia, interventricular septal defect, bulbous aortic arch, stenosis of ductus arteriosus, interrupted ossification of vertebral arch, vertebral and rib malformations, omphalocele, and gallbladder agenesis) and developmental variations. In pregnant rats, tacrolimus at oral doses of 3.2 mg/kg, 2.6 to 6.9 times the clinical dose range was associated with maternal toxicity, an increase in late resorptions, decreased numbers of live births, and decreased pup weight and viability. Tacrolimus, given orally to pregnant rats after organogenesis and during lactation at 1.0 and 3.2 mg/kg, 0.8 to 6.9 times the recommended clinical dose range was associated with reduced pup weights and pup viability (3.2 mg/kg only); among the high dose pups that died early, an increased incidence of kidney hydronephrosis was observed.

## 8.3 Nursing Mothers

Tacrolimus is excreted in human milk. As the effect of chronic exposure to tacrolimus in healthy infants is not established, patients maintained on Prograf should discontinue nursing taking into consideration importance of drug to the mother.



## 8.4 Pediatric Use

The safety and efficacy of Prograf in pediatric kidney and heart transplant patients have not been established. Successful liver transplants have been performed in pediatric patients (ages up to 16 years) using Prograf. Two randomized active-controlled trials of Prograf in primary liver transplantation included 56 pediatric patients. Thirty-one patients were randomized to Prograf-based and 25 to cyclosporine-based therapies. Additionally, a minimum of 122 pediatric patients were studied in an uncontrolled trial of tacrolimus in living related donor liver transplantation. Pediatric patients generally required higher doses of Prograf to maintain blood trough concentrations of tacrolimus similar to adult patients [*see Dosage and Administration (2.2)*].

## 8.5 Geriatric Use

Clinical trials of Prograf did not include sufficient numbers of subjects aged 65 and over to determine whether they respond differently from younger subjects. Other reported clinical experience has not identified differences in responses between the elderly and younger patients. In general, dose selection for an elderly patient should be cautious, usually starting at the low end of the dosing range, reflecting the greater frequency of decreased hepatic, renal, or cardiac function, and of concomitant disease or other drug therapy.

## 8.6 Use in Renal Impairment

The pharmacokinetics of Prograf in patients with renal impairment was similar to that in healthy volunteers with normal renal function. However, consideration should be given to dosing Prograf at the lower end of the therapeutic dosing range in patients who have received a liver or heart transplant and have pre-existing renal impairment. Further reductions in dose below the targeted range may be required [*see Dosage and Administration (2.3) and Clinical Pharmacology (12.3)*].

## 8.7 Use in Hepatic Impairment

The mean clearance of tacrolimus was substantially lower in patients with severe hepatic impairment (mean Child-Pugh score: >10) compared to healthy volunteers with normal hepatic function. Close monitoring of tacrolimus trough concentrations is warranted in patients with hepatic impairment [*see Clinical Pharmacology (12.3)*].

The use of Prograf in liver transplant recipients experiencing post-transplant hepatic impairment may be associated with increased risk of developing renal insufficiency related to high whole-blood trough concentrations of tacrolimus. These patients should be monitored closely and dosage adjustments should be considered. Some evidence suggests that lower doses should be used in these patients [*see Dosage and Administration (2.3) and Clinical Pharmacology (12.3)*].

## 10 OVERDOSAGE

Limited overdosage experience is available. Acute overdosages of up to 30 times the intended dose have been reported. Almost all cases have been asymptomatic and all patients recovered with no sequelae. Acute overdosage was sometimes followed by adverse reactions consistent with those listed in *Adverse Reactions (6)* (including tremors, abnormal renal function, hypertension, and peripheral edema); in one case of acute overdosage, transient urticaria and lethargy were observed. Based on the poor aqueous solubility and extensive erythrocyte and plasma protein binding, it is anticipated that tacrolimus is not dialyzable to any significant extent; there is no experience with charcoal hemoperfusion. The oral use of activated charcoal has been reported in treating acute overdoses, but experience has not been sufficient to warrant recommending its use. General supportive measures and treatment of specific symptoms should be followed in all cases of overdosage.

In acute oral and IV toxicity studies, mortalities were seen at or above the following doses: in adult rats, 52 times the recommended human oral dose; in immature rats, 16 times the recommended oral dose; and in adult rats, 16 times the recommended human IV dose (all based on body surface area corrections).

## 11 DESCRIPTION

Prograf is available for oral administration as capsules (tacrolimus capsules USP) containing the equivalent of 0.5 mg, 1 mg or 5 mg of anhydrous tacrolimus USP. Inactive ingredients include lactose monohydrate NF, hypromellose USP, croscarmellose sodium NF, and magnesium stearate NF. The 0.5 mg capsule shell contains gelatin NF, titanium dioxide

USP and ferric oxide NF, the 1 mg capsule shell contains gelatin NF and titanium dioxide USP, and the 5 mg capsule shell contains gelatin NF, titanium dioxide USP and ferric oxide NF.

Prograf is also available as a sterile solution (tacrolimus injection) containing the equivalent of 5 mg anhydrous tacrolimus USP in 1 mL for administration by intravenous infusion only. Each mL contains polyoxyl 60 hydrogenated castor oil (HCO-60), 200 mg, and dehydrated alcohol, USP, 80.0% v/v. Prograf injection must be diluted with 0.9% Sodium Chloride Injection or 5% Dextrose Injection before use.

Tacrolimus, previously known as FK506, is the active ingredient in Prograf. Tacrolimus is a macrolide immunosuppressant produced by *Streptomyces tsukubaensis*. Chemically, tacrolimus is designated as [3*S*-[3*R*\*[*E*(1*S*\*,3*S*\*,4*S*\*)], 4*S*\*,5*R*\*,8*S*\*,9*E*,12*R*\*,14*R*\*,15*S*\*,16*R*\*,18*S*\*,19*S*\*,26*aR*\*]] - 5,6,8,11,12,13,14,15,16,17,18,19,24,25,26,26*a*-hexadecahydro-5,19-dihydroxy-3-[2-(4-hydroxy-3-methoxycyclohexyl)-1-methylethenyl]-14,16-dimethoxy-4,10,12,18-tetramethyl-8-(2-propenyl)-15,19-epoxy-3*H*-pyrido[2,1-*c*][1,4]oxaazacyclotricosine-1,7,20,21(4*H*,23*H*)-tetrone, monohydrate.

The chemical structure of tacrolimus is:

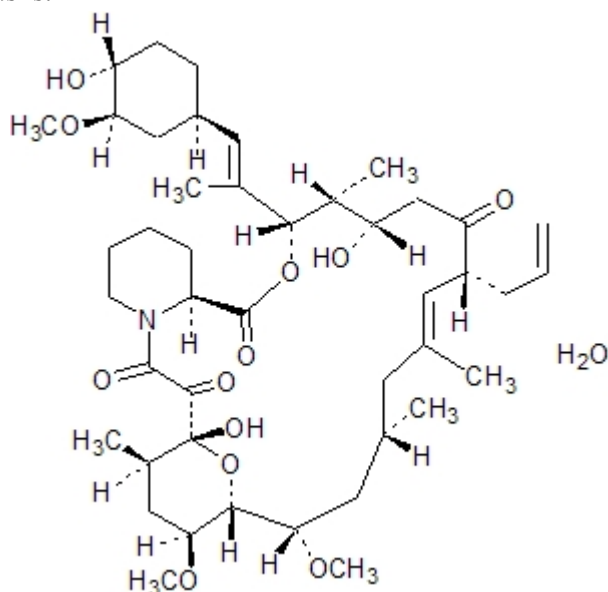

Tacrolimus has an empirical formula of  $C_{44}H_{69}NO_{12} \cdot H_2O$  and a formula weight of 822.03. Tacrolimus appears as white crystals or crystalline powder. It is practically insoluble in water, freely soluble in ethanol, and very soluble in methanol and chloroform.

## 12 CLINICAL PHARMACOLOGY

### 12.1 Mechanism of Action

Tacrolimus inhibits T-lymphocyte activation, although the exact mechanism of action is not known. Experimental evidence suggests that tacrolimus binds to an intracellular protein, FKBP-12. A complex of tacrolimus-FKBP-12, calcium, calmodulin, and calcineurin is then formed and the phosphatase activity of calcineurin inhibited. This effect may prevent the dephosphorylation and translocation of nuclear factor of activated T-cells (NF-AT), a nuclear component thought to initiate gene transcription for the formation of lymphokines (such as interleukin-2, gamma interferon). The net result is the inhibition of T-lymphocyte activation (i.e., immunosuppression).

Tacrolimus prolongs the survival of the host and transplanted graft in animal transplant models of liver, kidney, heart, bone marrow, small bowel and pancreas, lung and trachea, skin, cornea, and limb.

In animals, tacrolimus has been demonstrated to suppress some humoral immunity and, to a greater extent, cell-mediated reactions such as allograft rejection, delayed type hypersensitivity, collagen-induced arthritis, experimental allergic encephalomyelitis, and graft versus host disease.

### 12.3 Pharmacokinetics

Tacrolimus activity is primarily due to the parent drug. The pharmacokinetic parameters (mean±S.D.) of tacrolimus have been determined following intravenous (IV) and/or oral (PO) administration in healthy volunteers, and in kidney transplant, liver transplant, and heart transplant patients (Table 14).

**Table 14. Pharmacokinetics Parameters (mean±S.D.) of Tacrolimus in Healthy Volunteers and Patients**

| Population                       | N  | Route<br>(Dose)                                    | Parameters                  |                               |                             |                          |                               |                             |
|----------------------------------|----|--|-----------------------------|-------------------------------|-----------------------------|--------------------------|-------------------------------|-----------------------------|
|                                  |    |  | C <sub>max</sub><br>(ng/mL) | T <sub>max</sub><br>(hr)      | AUC<br>(ng•hr/mL)           | t <sub>1/2</sub><br>(hr) | CI<br>(L/hr/kg)               | V<br>(L/kg)                 |
| Healthy<br>Volunteers            | 8  | IV<br>(0.025 mg/kg/4hr)                            | a                           | a                             | 598 <sup>b</sup><br>± 125   | 34.2<br>± 7.7            | 0.040<br>± 0.009              | 1.91<br>± 0.31              |
|                                  | 16 | PO<br>(5 mg)                                       | 29.7<br>± 7.2               | 1.6<br>± 0.7                  | 243 <sup>c</sup><br>± 73    | 34.8<br>± 11.4           | 0.041 <sup>d</sup><br>± 0.008 | 1.94 <sup>d</sup><br>± 0.53 |
| Kidney<br>Transplant<br>Patients | 26 | IV<br>(0.02 mg/kg/12 hr)                           | a                           | a                             | 294 <sup>e</sup><br>± 262   | 18.8<br>± 16.7           | 0.083<br>± 0.050              | 1.41<br>± 0.66              |
|                                  |    | PO<br>(0.2 mg/kg/day)                              | 19.2<br>± 10.3              | 3.0                           | 203 <sup>e</sup><br>± 42    | f                        | f                             | f                           |
|                                  |    | PO<br>(0.3 mg/kg/day)                              | 24.2<br>± 15.8              | 1.5                           | 288 <sup>e</sup><br>± 93    | f                        | f                             | f                           |
| Liver<br>Transplant<br>Patients  | 17 | IV<br>(0.05 mg/kg/12 hr)                           | a                           | a                             | 3300 <sup>e</sup><br>± 2130 | 11.7<br>± 3.9            | 0.053<br>± 0.017              | 0.85<br>± 0.30              |
|                                  |    | PO<br>(0.3 mg/kg/day)                              | 68.5<br>± 30.0              | 2.3<br>± 1.5                  | 519 <sup>e</sup><br>± 179   | f                        | f                             | f                           |
| Heart<br>Transplant<br>Patients  | 11 | IV<br>(0.01 mg/kg/day as a<br>continuous infusion) | a                           | a                             | 954 <sup>g</sup><br>± 334   | 23.6<br>± 9.22           | 0.051<br>± 0.015              | f                           |
|                                  | 11 | PO<br>(0.075 mg/kg/day) <sup>h</sup>               | 14.7 ± 7.79                 | 2.1<br>[0.5-6.0] <sup>i</sup> | 82.7 <sup>j</sup><br>± 63.2 | a                        | f                             | f                           |
|                                  | 14 | PO<br>(0.15 mg/kg/day) <sup>h</sup>                | 24.5 ± 13.7                 | 1.5<br>[0.4-4.0] <sup>i</sup> | 142 <sup>j</sup> ± 116      | a                        | f                             | f                           |

a) not applicable

b) AUC<sub>0-120</sub>

c) AUC<sub>0-72</sub>

d) Corrected for individual bioavailability

e) AUC<sub>0-inf</sub>

f) not available

g) AUC<sub>0-t</sub>

h) Determined after the first dose

i) Median [range]

j) AUC<sub>0-12</sub>

Due to intersubject variability in tacrolimus pharmacokinetics, individualization of dosing regimen is necessary for optimal therapy [see *Dosage and Administration (2.6)*]. Pharmacokinetic data indicate that whole blood concentrations rather than plasma concentrations serve as the more appropriate sampling compartment to describe tacrolimus pharmacokinetics.

### *Absorption*

Absorption of tacrolimus from the gastrointestinal tract after oral administration is incomplete and variable. The absolute bioavailability of tacrolimus was  $17\pm 10\%$  in adult kidney transplant patients (N=26),  $22\pm 6\%$  in adult liver transplant patients (N=17),  $23\pm 9\%$  in adult heart transplant patients (N=11) and  $18\pm 5\%$  in healthy volunteers (N=16).

A single dose trial conducted in 32 healthy volunteers established the bioequivalence of the 1 mg and 5 mg capsules. Another single dose trial in 32 healthy volunteers established the bioequivalence of the 0.5 mg and 1 mg capsules. Tacrolimus maximum blood concentrations ( $C_{\max}$ ) and area under the curve (AUC) appeared to increase in a dose-proportional fashion in 18 fasted healthy volunteers receiving a single oral dose of 3, 7, and 10 mg.

In 18 kidney transplant patients, tacrolimus trough concentrations from 3 to 30 ng/mL measured at 10-12 hours post-dose ( $C_{\min}$ ) correlated well with the AUC (correlation coefficient 0.93). In 24 liver transplant patients over a concentration range of 10 to 60 ng/mL, the correlation coefficient was 0.94. In 25 heart transplant patients over a concentration range of 2 to 24 ng/mL, the correlation coefficient was 0.89 after an oral dose of 0.075 or 0.15 mg/kg/day at steady-state.

### *Food Effects*

The rate and extent of tacrolimus absorption were greatest under fasted conditions. The presence and composition of food decreased both the rate and extent of tacrolimus absorption when administered to 15 healthy volunteers.

The effect was most pronounced with a high-fat meal (848 kcal, 46% fat): mean AUC and  $C_{\max}$  were decreased 37% and 77%, respectively;  $T_{\max}$  was lengthened 5-fold. A high-carbohydrate meal (668 kcal, 85% carbohydrate) decreased mean AUC and mean  $C_{\max}$  by 28% and 65%, respectively.

In healthy volunteers (N=16), the time of the meal also affected tacrolimus bioavailability. When given immediately following the meal, mean  $C_{\max}$  was reduced 71%, and mean AUC was reduced 39%, relative to the fasted condition. When administered 1.5 hours following the meal, mean  $C_{\max}$  was reduced 63%, and mean AUC was reduced 39%, relative to the fasted condition.

In 11 liver transplant patients, Prograf administered 15 minutes after a high fat (400 kcal, 34% fat) breakfast, resulted in decreased AUC ( $27\pm 18\%$ ) and  $C_{\max}$  ( $50\pm 19\%$ ), as compared to a fasted state.

Prograf capsules should be taken consistently every day either with or without food because the presence and composition of food decreases the bioavailability of Prograf [see *Dosage and Administration (2.5)*].

### *Distribution*

The plasma protein binding of tacrolimus is approximately 99% and is independent of concentration over a range of 5-50 ng/mL. Tacrolimus is bound mainly to albumin and alpha-1-acid glycoprotein, and has a high level of association with erythrocytes. The distribution of tacrolimus between whole blood and plasma depends on several factors, such as hematocrit, temperature at the time of plasma separation, drug concentration, and plasma protein concentration. In a U.S. trial, the ratio of whole blood concentration to plasma concentration averaged 35 (range 12 to 67).

### *Metabolism*

Tacrolimus is extensively metabolized by the mixed-function oxidase system, primarily the cytochrome P-450 system (CYP3A). A metabolic pathway leading to the formation of 8 possible metabolites has been proposed. Demethylation and hydroxylation were identified as the primary mechanisms of biotransformation in vitro. The major metabolite identified in incubations with human liver microsomes is 13-demethyl tacrolimus. In in vitro studies, a 31-demethyl metabolite has been reported to have the same activity as tacrolimus.

### *Excretion*

The mean clearance following IV administration of tacrolimus is 0.040, 0.083, and 0.053, and 0.051 L/hr/kg in healthy volunteers, adult kidney transplant patients, adult liver transplant patients, and adult heart transplant patients, respectively. In man, less than 1% of the dose administered is excreted unchanged in urine.

In a mass balance study of IV administered radiolabeled tacrolimus to 6 healthy volunteers, the mean recovery of radiolabel was 77.8±12.7%. Fecal elimination accounted for 92.4±1.0% and the elimination half-life based on radioactivity was 48.1±15.9 hours whereas it was 43.5±11.6 hours based on tacrolimus concentrations. The mean clearance of radiolabel was 0.029±0.015 L/hr/kg and clearance of tacrolimus was 0.029±0.009 L/hr/kg. When administered PO, the mean recovery of the radiolabel was 94.9±30.7%. Fecal elimination accounted for 92.6±30.7%, urinary elimination accounted for 2.3±1.1% and the elimination half-life based on radioactivity was 31.9±10.5 hours whereas it was 48.4±12.3 hours based on tacrolimus concentrations. The mean clearance of radiolabel was 0.226±0.116 L/hr/kg and clearance of tacrolimus 0.172±0.088 L/hr/kg.

### ***Specific Populations***

#### **Pediatric**

Pharmacokinetics of tacrolimus have been studied in liver transplantation patients, 0.7 to 13.2 years of age. Following IV administration of a 0.037 mg/kg/day dose to 12 pediatric patients, mean terminal half-life, volume of distribution and clearance were 11.5±3.8 hours, 2.6±2.1 L/kg and 0.138±0.071 L/hr/kg, respectively. Following oral administration to 9 patients, mean AUC and C<sub>max</sub> were 337±167 ng·hr/mL and 48.4±27.9 ng/mL, respectively. The absolute bioavailability was 31±24%.

Whole blood trough concentrations from 31 patients less than 12 years old showed that pediatric patients needed higher doses than adults to achieve similar tacrolimus trough concentrations [*see Dosage and Administration (2.2)*].

Pharmacokinetics of tacrolimus have also been studied in kidney transplantation patients, 8.2±2.4 years of age. Following IV infusion of a 0.06 (range 0.06 – 0.09) mg/kg/day to 12 pediatric patients (8 male and 4 female), mean terminal half-life and clearance were 10.2±5.0 (range 3.4-25) hours and 0.12±0.04 (range 0.06-0.17) L/hr/kg, respectively. Following oral administration to the same patients, mean AUC and C<sub>max</sub> were 181±65 (range 81-300) ng·hr/mL and 30±11 (range 14-49) ng/mL, respectively. The absolute bioavailability was 19±14 (range 5.2-56) %.

#### **Renal and Hepatic Impairment**

The mean pharmacokinetic parameters for tacrolimus following single administrations to patients with renal and hepatic impairment are given in Table 15.

**Table 15. Pharmacokinetic In Renal and Hepatic Impaired Patients**

| <b>Population<br/>(No. of Patients)</b>      | <b>Dose</b>                | <b>AUC<sub>0-t</sub><br/>(ng·hr/mL)</b> | <b>t<sub>1/2</sub><br/>(hr)</b> | <b>V<br/>(L/kg)</b>  | <b>CI<br/>(L/hr/kg)</b>  |
|--|----------------------------|---|---------------------------------|----------------------|--------------------------|
| Renal<br>Impairment<br>(n=12)                | 0.02<br>mg/kg/4hr<br>IV    | 393±123<br>(t=60 hr)                    | 26.3 ±9.2                       | 1.07±0.20            | 0.038±0.014              |
| Mild Hepatic<br>Impairment<br>(n=6)          | 0.02<br>mg/kg/4hr<br>IV    | 367±107<br>(t=72 hr)                    | 60.6±43.8<br>Range: 27.8 – 141  | 3.1±1.6              | 0.042±0.02               |
|  | 7.7 mg<br>PO               | 488±320<br>(t=72 hr)                    | 66.1±44.8<br>Range: 29.5 – 138  | 3.7±4.7 <sup>a</sup> | 0.034±0.019 <sup>a</sup> |
| Severe<br>Hepatic<br>Impairment<br>(n=6, IV) | 0.02 mg/kg/4hr<br>IV (n=2) | 762±204<br>(t=120 hr)                   | 198±158<br>Range:81 – 436       | 3.9±1.0              | 0.017±0.013              |
|  | 0.01 mg/kg/8hr<br>IV (n=4) | 289±117<br>(t=144 hr)                   |                                 |                      |                          |

| Population<br>(No. of Patients) | Dose             | AUC <sub>0-t</sub><br>(ng·hr/mL) | t <sub>1/2</sub><br>(hr)  | V<br>(L/kg)          | CI<br>(L/hr/kg)          |
|---------------------------------|------------------|----------------------------------|---------------------------|----------------------|--------------------------|
| (n=5, PO) <sup>b</sup>          | 8 mg PO<br>(n=1) | 658<br>(t=120 hr)                | 119±35<br>Range: 85 – 178 | 3.1±3.4 <sup>a</sup> | 0.016±0.011 <sup>a</sup> |
|                                 | 5 mg PO<br>(n=4) | 533±156<br>(t=144 hr)            |                           |                      |                          |
|                                 | 4 mg PO<br>(n=1) |                                  |                           |                      |                          |

a) corrected for bioavailability

b) 1 patient did not receive the PO dose

**Renal Impairment:** Tacrolimus pharmacokinetics following a single IV administration were determined in 12 patients (7 not on dialysis and 5 on dialysis, serum creatinine of 3.9±1.6 and 12.0±2.4 mg/dL, respectively) prior to their kidney transplant. The pharmacokinetic parameters obtained were similar for both groups. The mean clearance of tacrolimus in patients with renal dysfunction was similar to that in normal volunteers (Table 15) [see *Dosage and Administration (2.3) and Use in Specific Populations (8.6)*].

**Hepatic Impairment:** Tacrolimus pharmacokinetics have been determined in six patients with mild hepatic dysfunction (mean Pugh score: 6.2) following single IV and oral administrations. The mean clearance of tacrolimus in patients with mild hepatic dysfunction was not substantially different from that in normal volunteers (see previous table). Tacrolimus pharmacokinetics were studied in 6 patients with severe hepatic dysfunction (mean Pugh score: >10). The mean clearance was substantially lower in patients with severe hepatic dysfunction, irrespective of the route of administration [see *Dosage and Administration (2.4) and Use in Specific Populations (8.7)*].

### Race

The pharmacokinetics of tacrolimus have been studied following single IV and oral administration of Prograf to 10 African-American, 12 Latino-American, and 12 Caucasian healthy volunteers. There were no significant pharmacokinetic differences among the three ethnic groups following a 4-hour IV infusion of 0.015 mg/kg. However, after single oral administration of 5 mg, mean (±SD) tacrolimus C<sub>max</sub> in African-Americans (23.6±12.1 ng/mL) was significantly lower than in Caucasians (40.2±12.6 ng/mL) and the Latino-Americans (36.2±15.8 ng/mL) (p<0.01). Mean AUC<sub>0-inf</sub> tended to be lower in African-Americans (203±115 ng·hr/mL) than Caucasians (344±186 ng·hr/mL) and Latino-Americans (274±150 ng·hr/mL). The mean (±SD) absolute oral bioavailability (F) in African-Americans (12±4.5%) and Latino-Americans (14±7.4%) was significantly lower than in Caucasians (19±5.8%, p=0.011). There was no significant difference in mean terminal T<sub>1/2</sub> among the three ethnic groups (range from approximately 25 to 30 hours). A retrospective comparison of African-American and Caucasian kidney transplant patients indicated that African-American patients required higher tacrolimus doses to attain similar trough concentrations [see *Dosage and Administration (2.1)*].

### Gender

A formal trial to evaluate the effect of gender on tacrolimus pharmacokinetics has not been conducted, however, there was no difference in dosing by gender in the kidney transplant trial. A retrospective comparison of pharmacokinetics in healthy volunteers, and in kidney, liver and heart transplant patients indicated no gender-based differences.

### **Drug Interactions**

Frequent monitoring of whole blood concentrations and appropriate dosage adjustments of tacrolimus are recommended when concomitant use of the following drugs with tacrolimus is initiated or discontinued [see *Drug Interactions (7)*].

**Telaprevir:** In a single dose study in 9 healthy volunteers, coadministration of tacrolimus (0.5 mg single dose) with telaprevir (750 mg three times daily for 13 days) increased the tacrolimus dose-normalized C<sub>max</sub> by 9.3-fold and AUC by 70-fold compared to tacrolimus alone [see *Drug Interactions (7.3)*].

**Boceprevir:** In a single dose study in 12 subjects, coadministration of tacrolimus (0.5 mg single dose) with boceprevir (800 mg three times daily for 11 days) increased tacrolimus  $C_{max}$  by 9.9-fold and AUC by 17-fold compared to tacrolimus alone [see *Drug Interactions* (7.3)].

**Nelfinavir:** Based on a clinical study of 5 liver transplant recipients, co-administration of tacrolimus with nelfinavir increased blood concentrations of tacrolimus significantly and, as a result, a reduction in the tacrolimus dose by an average of 16-fold was needed to maintain mean trough tacrolimus blood concentrations of 9.7 ng/mL. It is recommended to avoid concomitant use of Prograf and nelfinavir unless the benefits outweigh the risks [see *Drug Interactions* (7.3)].

**Rifampin:** In a study of 6 normal volunteers, a significant decrease in tacrolimus oral bioavailability ( $14\pm 6\%$  vs.  $7\pm 3\%$ ) was observed with concomitant rifampin administration (600 mg). In addition, there was a significant increase in tacrolimus clearance ( $0.036\pm 0.008$  L/hr/kg vs.  $0.053\pm 0.010$  L/hr/kg) with concomitant rifampin administration [see *Drug Interactions* (7.7)].

**Magnesium-aluminum-hydroxide:** In a single-dose crossover study in healthy volunteers, co-administration of tacrolimus and magnesium-aluminum-hydroxide resulted in a 21% increase in the mean tacrolimus AUC and a 10% decrease in the mean tacrolimus  $C_{max}$  relative to tacrolimus administration alone [see *Drug Interactions* (7.10)].

**Ketoconazole:** In a study of 6 normal volunteers, a significant increase in tacrolimus oral bioavailability ( $14\pm 5\%$  vs.  $30\pm 8\%$ ) was observed with concomitant ketoconazole administration (200 mg). The apparent oral clearance of tacrolimus during ketoconazole administration was significantly decreased compared to tacrolimus alone ( $0.430\pm 0.129$  L/hr/kg vs.  $0.148\pm 0.043$  L/hr/kg). Overall, IV clearance of tacrolimus was not significantly changed by ketoconazole co-administration, although it was highly variable between patients [see *Drug Interactions* (7.4)].

**Voriconazole** (see complete prescribing information for VFEND<sup>®</sup>): Repeat oral dose administration of voriconazole (400 mg every 12 hours for one day, then 200 mg every 12 hours for 6 days) increased tacrolimus (0.1 mg/kg single dose)  $C_{max}$  and AUC $_{\tau}$  in healthy subjects by an average of 2-fold (90% CI: 1.9, 2.5) and 3-fold (90% CI: 2.7, 3.8), respectively [see *Drug Interactions* (7.4)].

**Posaconazole** (see complete prescribing information for Noxafil<sup>®</sup>): Repeat oral administration of posaconazole (400 mg twice daily for 7 days) increased tacrolimus (0.05 mg/kg single dose)  $C_{max}$  and AUC in healthy subjects by an average of 2-fold (90% CI: 2.01, 2.42) and 4.5-fold (90% CI 4.03, 5.19), respectively [see *Drug Interactions* (7.4)].

**Caspofungin** (see complete prescribing information for CANCIDAS<sup>®</sup>): Caspofungin reduced the blood AUC $_{0-12}$  of tacrolimus by approximately 20%, peak blood concentration ( $C_{max}$ ) by 16%, and 12-hour blood concentration ( $C_{12hr}$ ) by 26% in healthy adult subjects when tacrolimus (2 doses of 0.1 mg/kg 12 hours apart) was administered on the 10th day of CANCIDAS<sup>®</sup> 70 mg daily, as compared to results from a control period in which tacrolimus was administered alone [see *Drug Interactions* (7.4)].

## 13 NONCLINICAL TOXICOLOGY

### 13.1 Carcinogenesis, Mutagenesis, Impairment of Fertility

Carcinogenicity studies were conducted in male and female rats and mice. In the 80-week mouse oral study and in the 104-week rat oral study, no relationship of tumor incidence to tacrolimus dosage was found. The highest dose used in the mouse was 3.0 mg/kg/day (0.9 to 2.2 times the AUC at clinical doses of 0.075 to 0.2 mg/kg/day) and in the rat was 5.0 mg/kg/day (0.265 to 0.65 times the AUC at clinical doses of 0.075 to 0.2 mg/kg/day) [see *Boxed Warning and Warnings and Precautions* (5.2)].

A 104-week dermal carcinogenicity study was performed in mice with tacrolimus ointment (0.03% - 3%), equivalent to tacrolimus doses of 1.1-118 mg/kg/day or 3.3-354 mg/m<sup>2</sup>/day. In the study, the incidence of skin tumors was minimal and the topical application of tacrolimus was not associated with skin tumor formation under ambient room lighting. However, a statistically significant elevation in the incidence of pleomorphic lymphoma in high dose male (25/50) and female

animals (27/50) and in the incidence of undifferentiated lymphoma in high dose female animals (13/50) was noted in the mouse dermal carcinogenicity study. Lymphomas were noted in the mouse dermal carcinogenicity study at a daily dose of 3.5 mg/kg (0.1% tacrolimus ointment). No drug-related tumors were noted in the mouse dermal carcinogenicity study at a daily dose of 1.1 mg/kg (0.03% tacrolimus ointment). The relevance of topical administration of tacrolimus in the setting of systemic tacrolimus use is unknown.

The implications of these carcinogenicity studies to the human condition are limited; doses of tacrolimus were administered that likely induced immunosuppression in these animals impairing their immune system's ability to inhibit unrelated carcinogenesis.

No evidence of genotoxicity was seen in bacterial (*Salmonella* and *E. coli*) or mammalian (Chinese hamster lung-derived cells) in vitro assays of mutagenicity, the in vitro CHO/HGPRT assay of mutagenicity, or in vivo clastogenicity assays performed in mice; tacrolimus did not cause unscheduled DNA synthesis in rodent hepatocytes.

Tacrolimus given orally at 1.0 mg/kg (0.8 to 2.2 times the clinical dose range of 0.075 to 0.2 mg/kg/day based on body surface area) to male and female rats, prior to and during mating, as well as to dams during gestation and lactation, was associated with embryoletality and adverse effects on female reproduction. Effects on female reproductive function (parturition) and embryoletal effects were indicated by a higher rate of pre-implantation loss and increased numbers of undelivered and nonviable pups. When given at 3.2 mg/kg (2.6 to 6.9 times the clinical dose range based on body surface area), tacrolimus was associated with maternal and paternal toxicity as well as reproductive toxicity including marked adverse effects on estrus cycles, parturition, pup viability, and pup malformations.

## 14 CLINICAL STUDIES

### 14.1 Kidney Transplantation

#### *Prograf/azathioprine (AZA)*

Prograf-based immunosuppression in conjunction with azathioprine and corticosteroids following kidney transplantation was assessed in a randomized, multicenter, non-blinded, prospective trial. There were 412 kidney transplant patients enrolled at 19 clinical sites in the United States. Study therapy was initiated when renal function was stable as indicated by a serum creatinine  $\leq 4$  mg/dL (median of 4 days after transplantation, range 1 to 14 days). Patients less than 6 years of age were excluded.

There were 205 patients randomized to Prograf-based immunosuppression and 207 patients were randomized to cyclosporine-based immunosuppression. All patients received prophylactic induction therapy consisting of an antilymphocyte antibody preparation, corticosteroids and azathioprine. Overall 1 year patient and graft survival was 96.1% and 89.6%, respectively.

Data from this trial of Prograf in conjunction with azathioprine indicate that during the first three months of that trial, 80% of the patients maintained trough concentrations between 7-20 ng/mL, and then between 5-15 ng/mL, through 1 year.

#### *Prograf/mycophenolate mofetil (MMF)*

Prograf-based immunosuppression in conjunction with MMF, corticosteroids, and induction has been studied. In a randomized, open-label, multi-center trial (Study 1), 1589 kidney transplant patients received Prograf (Group C, n=401), sirolimus (Group D, n=399), or one of two cyclosporine (CsA) regimens (Group A, n=390 and Group B, n=399) in combination with MMF and corticosteroids; all patients, except those in one of the two cyclosporine groups, also received induction with daclizumab. The trial was conducted outside the United States; the trial population was 93% Caucasian. In this trial, mortality at 12 months in patients receiving Prograf/MMF was similar (3%) compared to patients receiving cyclosporine/MMF (3% and 2%) or sirolimus/MMF (3%). Patients in the Prograf group exhibited higher estimated creatinine clearance rates (eCL<sub>cr</sub>) using the Cockcroft-Gault formula (Table 16) and experienced fewer efficacy failures, defined as biopsy proven acute rejection (BPAR), graft loss, death, and/or lost to follow-up (Table 17) in comparison to each of the other three groups. Patients randomized to Prograf/MMF were more likely to develop diarrhea and diabetes after the transplantation and experienced similar rates of infections compared to patients randomized to either cyclosporine/MMF regimen [see *Adverse Reactions (6.1)*].



**Table 16. Estimated Creatinine Clearance at 12 Months (Study 1)**

| Group                      | eCL <sub>cr</sub> [mL/min] at Month 12 <sup>a</sup> |      |      |        |  |
|----------------------------|---|------|------|--------|--|
|                            | N   | MEAN | SD   | MEDIAN | Treatment Difference with Group C (99.2% CI <sup>b</sup> ) |
| (A) CsA/MMF/CS             | 390   | 56.5 | 25.8 | 56.9   | -8.6 (-13.7, -3.7)   |
| (B) CsA/MMF/CS/Daclizumab  | 399   | 58.9 | 25.6 | 60.9   | -6.2 (-11.2, -1.2)   |
| (C) Tac/MMF/CS/Daclizumab  | 401   | 65.1 | 27.4 | 66.2   | -  |
| (D) Siro/MMF/CS/Daclizumab | 399   | 56.2 | 27.4 | 57.3   | -8.9 (-14.1, -3.9)   |
| Total                      | 1589  | 59.2 | 26.8 | 60.5   |  |

Key: CsA=Cyclosporine, CS=Corticosteroids, Tac=Tacrolimus, Siro=Sirolimus

<sup>a)</sup> All death/graft loss (n=41, 27, 23 and 42 in Groups A, B, C and D) and patients whose last recorded creatinine values were prior to month 3 visit (n=10, 9, 7 and 9 in Groups A, B, C and D, respectively) were imputed with Glomerular Filtration Rate (GFR) of 10 mL/min; a subject's last observed creatinine value from month 3 on was used for the remainder of subjects with missing creatinine at month 12 (n=11, 12, 15 and 19 for Groups A, B, C and D, respectively). Weight was also imputed in the calculation of estimated GFR, if missing.

<sup>b)</sup> Adjusted for multiple (6) pairwise comparisons using Bonferroni corrections.

**Table 17. Incidence of BPAR, Graft Loss, Death or Loss to Follow-up at 12 Months (Study 1)**

|   | Group A<br>N=390       | Group B<br>N=399       | Group C<br>N=401 | Group D<br>N=399        |
|---|------------------------|------------------------|------------------|-------------------------|
| Overall Failure   | 141 (36.2%)            | 126 (31.6%)            | 82 (20.4%)       | 185 (46.4%)             |
| Components of efficacy failure  |                        |                        |                  |                         |
| BPAR  | 113 (29.0%)            | 106 (26.6%)            | 60 (15.0%)       | 152 (38.1%)             |
| Graft loss excluding death  | 28 (7.2%)              | 20 (5.0%)              | 12 (3.0%)        | 30 (7.5%)               |
| Mortality   | 13 (3.3%)              | 7 (1.8%)               | 11 (2.7%)        | 12 (3.0%)               |
| Lost to follow-up   | 5 (1.3%)               | 7 (1.8%)               | 5 (1.3%)         | 6 (1.5%)                |
| Treatment Difference of efficacy failure compared to Group C (99.2% CI <sup>a</sup> ) | 15.8%<br>(7.1%, 24.3%) | 11.2%<br>(2.7%, 19.5%) | -                | 26.0%<br>(17.2%, 34.7%) |

Key: Group A = CsA/MMF/CS, B = CsA/MMF/CS/Daclizumab, C = Tac/MMF/CS/Daclizumab, and D = Siro/MMF/CS/Daclizumab

<sup>a)</sup> Adjusted for multiple (6) pairwise comparisons using Bonferroni corrections.

The protocol-specified target tacrolimus trough concentrations ( $C_{\text{trough}, \text{Tac}}$ ) were 3-7 ng/mL; however, the observed median  $C_{\text{troughs}, \text{Tac}}$  approximated 7 ng/mL throughout the 12 month trial (Table 18). Approximately 80% of patients maintained tacrolimus whole blood concentrations between 4-11 ng/mL through 1 year post-transplant.

**Table 18. Tacrolimus Whole Blood Trough Concentrations (Study 1)**

| Time            | Median (P10-P90 <sup>a</sup> ) tacrolimus whole blood trough concentrations (ng/mL) |
|-----------------|---|
| Day 30 (N=366)  | 6.9 (4.4 – 11.3)  |
| Day 90 (N=351)  | 6.8 (4.1 – 10.7)  |
| Day 180 (N=355) | 6.5 (4.0 – 9.6)   |
| Day 365 (N=346) | 6.5 (3.8 – 10.0)  |

<sup>a)</sup> 10 to 90<sup>th</sup> Percentile: range of  $C_{\text{trough}, \text{Tac}}$  that excludes lowest 10% and highest 10% of  $C_{\text{trough}, \text{Tac}}$

The protocol-specified target cyclosporine trough concentrations ( $C_{\text{trough}, \text{CsA}}$ ) for Group B were 50-100 ng/mL; however, the observed median  $C_{\text{troughs}, \text{CsA}}$  approximated 100 ng/mL throughout the 12 month trial. The protocol-specified target  $C_{\text{troughs}, \text{CsA}}$  for Group A were 150-300 ng/mL for the first 3 months and 100-200 ng/mL from month 4 to month 12; the observed median  $C_{\text{troughs}, \text{CsA}}$  approximated 225 ng/mL for the first 3 months and 140 ng/mL from month 4 to month 12.

While patients in all groups started MMF at 1 gram twice daily, the MMF dose was reduced to less than 2 g per day in 63% of patients in the tacrolimus treatment arm by month 12 (Table 19); approximately 50% of these MMF dose reductions were due to adverse reactions. By comparison, the MMF dose was reduced to less than 2 g per day in 49% and 45% of patients in the two cyclosporine arms (Group A and Group B, respectively), by month 12 and approximately 40% of MMF dose reductions were due to adverse reactions.

**Table 19. MMF Dose Over Time in Prograf/MMF (Group C) (Study 1)**

| Time period (Days) | Time-averaged MMF dose (grams per day) <sup>a</sup> |     |                  |
|--------------------|---|-----|------------------|
|                    | Less than 2.0                                       | 2.0 | Greater than 2.0 |
| 0-30 (N=364)       | 37%   | 60% | 2%               |
| 0-90 (N=373)       | 47%   | 51% | 2%               |
| 0-180 (N=377)      | 56%   | 42% | 2%               |
| 0-365 (N=380)      | 63%   | 36% | 1%               |

Key: Time-averaged MMF dose = (total MMF dose)/(duration of treatment)

<sup>a</sup> Percentage of patients for each time-averaged MMF dose range during various treatment periods. Administration of 2 g per day of time-averaged MMF dose means that MMF dose was not reduced in those patients during the treatment periods.

In a second randomized, open-label, multi-center trial (Study 2), 424 kidney transplant patients received Prograf (N=212) or cyclosporine (N=212) in combination with MMF 1 gram twice daily, basiliximab induction, and corticosteroids. In this trial, the rate for the combined endpoint of BPAR, graft failure, death, and/or lost to follow-up at 12 months in the Prograf/MMF group was similar to the rate in the cyclosporine/MMF group. There was, however, an imbalance in mortality at 12 months in those patients receiving Prograf/MMF (4%) compared to those receiving cyclosporine/MMF (2%), including cases attributed to overimmunosuppression (Table 20).

**Table 20. Incidence of BPAR, Graft Loss, Death or Loss to Follow-up at 12 Months (Study 2)**

|   | Prograf/MMF (N=212) | Cyclosporine/MMF (N=212) |
|---|---------------------|--------------------------|
| Overall Failure   | 32 (15.1%)          | 36 (17.0%)               |
| Components of efficacy failure  |                     |                          |
| BPAR  | 16 (7.5%)           | 29 (13.7%)               |
| Graft loss excluding death  | 6 (2.8%)            | 4 (1.9%)                 |
| Mortality   | 9 (4.2%)            | 5 (2.4%)                 |
| Lost to follow-up   | 4 (1.9%)            | 1 (0.5%)                 |
| Treatment Difference of efficacy failure compared to Prograf/MMF group (95% CI <sup>a</sup> ) |                     | 1.9% (-5.2%, 9.0%)       |

<sup>a</sup> 95% confidence interval calculated using Fisher's Exact Test

The protocol-specified target tacrolimus whole blood trough concentrations ( $C_{\text{trough}, \text{Tac}}$ ) in Study 2 were 7-16 ng/mL for the first three months and 5-15 ng/mL thereafter. The observed median  $C_{\text{troughs}, \text{Tac}}$  approximated 10 ng/mL during the first three months and 8 ng/mL from month 4 to month 12 (Table 21). Approximately 80% of patients maintained tacrolimus whole trough blood concentrations between 6 to 16 ng/mL during months 1 through 3 and, then, between 5 to 12 ng/mL from month 4 through 1 year.

**Table 21. Tacrolimus Whole Blood Trough Concentrations (Study 2)**

| Time            | Median (P10-P90) <sup>a</sup> tacrolimus whole blood trough concentrations (ng/mL) |
|-----------------|--|
| Day 30 (N=174)  | 10.5 (6.3 – 16.8)  |
| Day 60 (N=179)  | 9.2 (5.9 – 15.3)   |
| Day 120 (N=176) | 8.3 (4.6 – 13.3)   |
| Day 180 (N=171) | 7.8 (5.5 – 13.2)   |
| Day 365 (N=178) | 7.1 (4.2 – 12.4)   |

<sup>a</sup> 10 to 90<sup>th</sup> Percentile: range of  $C_{\text{trough}, \text{Tac}}$  that excludes lowest 10% and highest 10% of  $C_{\text{trough}, \text{Tac}}$

The protocol-specified target cyclosporine whole blood concentrations ( $C_{\text{trough,CsA}}$ ) were 125 to 400 ng/mL for the first three months, and 100 to 300 ng/mL thereafter. The observed median  $C_{\text{troughs, CsA}}$  approximated 280 ng/mL during the first three months and 190 ng/mL from month 4 to month 12.

Patients in both groups started MMF at 1 gram twice daily. The MMF dose was reduced to less than 2 grams per day by month 12 in 62% of patients in the Prograf/MMF group (Table 22) and in 47% of patients in the cyclosporine/MMF group. Approximately 63% and 55% of these MMF dose reductions were because of adverse reactions in the Prograf/MMF group and the cyclosporine/MMF group, respectively [see *Adverse Reactions (6.1)*].

**Table 22. MMF Dose Over Time in the Prograf/MMF Group (Study 2)**

| Time period (Days) | Time-averaged MMF dose (g/day) <sup>a</sup> |     |                  |
|--------------------|---|-----|------------------|
|                    | Less than 2.0                               | 2.0 | Greater than 2.0 |
| 0-30 (N=212)       | 25%   | 69% | 6%               |
| 0-90 (N=212)       | 41%   | 53% | 6%               |
| 0-180 (N=212)      | 52%   | 41% | 7%               |
| 0-365 (N=212)      | 62%   | 34% | 4%               |

Key: Time-averaged MMF dose=(total MMF dose)/(duration of treatment)

<sup>a)</sup> Percentage of patients for each time-averaged MMF dose range during various treatment periods. Two grams per day of time-averaged MMF dose means that MMF dose was not reduced in those patients during the treatment periods.

## 14.2 Liver Transplantation

The safety and efficacy of Prograf-based immunosuppression following orthotopic liver transplantation were assessed in two prospective, randomized, non-blinded multicenter trials. The active control groups were treated with a cyclosporine-based immunosuppressive regimen (CsA/AZA). Both trials used concomitant adrenal corticosteroids as part of the immunosuppressive regimens. These trials compared patient and graft survival rates at 12 months following transplantation.

In one trial, 529 patients were enrolled at 12 clinical sites in the United States; prior to surgery, 263 were randomized to the Prograf-based immunosuppressive regimen and 266 to the CsA/AZA. In 10 of the 12 sites, the same CsA/AZA protocol was used, while 2 sites used different control protocols. This trial excluded patients with renal dysfunction, fulminant hepatic failure with Stage IV encephalopathy, and cancers; pediatric patients ( $\leq 12$  years old) were allowed.

In the second trial, 545 patients were enrolled at 8 clinical sites in Europe; prior to surgery, 270 were randomized to the Prograf-based immunosuppressive regimen and 275 to CsA/AZA. In this trial, each center used its local standard CsA/AZA protocol in the active-control arm. This trial excluded pediatric patients, but did allow enrollment of subjects with renal dysfunction, fulminant hepatic failure in Stage IV encephalopathy, and cancers other than primary hepatic with metastases.

One-year patient survival and graft survival in the Prograf-based treatment groups were similar to those in the CsA/AZA treatment groups in both trials. The overall 1-year patient survival (CsA/AZA and Prograf-based treatment groups combined) was 88% in the U.S. trial and 78% in the European trial. The overall 1-year graft survival (CsA/AZA and Prograf-based treatment groups combined) was 81% in the U.S. trial and 73% in the European trial. In both trials, the median time to convert from IV to oral Prograf dosing was 2 days.

Although there is a lack of direct correlation between tacrolimus concentrations and drug efficacy, data from clinical trials of liver transplant patients have shown an increasing incidence of adverse reactions with increasing trough blood concentrations. Most patients are stable when trough whole blood concentrations are maintained between 5 to 20 ng/mL. Long-term post-transplant patients often are maintained at the low end of this target range.

Data from the U.S. clinical trial show that the median trough blood concentrations, measured at intervals from the second week to one year post-transplantation ranged from 9.8 ng/mL to 19.4 ng/mL.

## 14.3 Heart Transplantation



Two open-label, randomized, comparative trials evaluated the safety and efficacy of Prograf-based and cyclosporine-based immunosuppression in primary orthotopic heart transplantation. In a trial conducted in Europe, 314 patients received a regimen of antibody induction, corticosteroids and azathioprine in combination with Prograf or cyclosporine modified for 18 months. In a 3-arm trial conducted in the US, 331 patients received corticosteroids and Prograf plus sirolimus, Prograf plus mycophenolate mofetil (MMF) or cyclosporine modified plus MMF for 1 year.

In the European trial, patient/graft survival at 18 months post-transplant was similar between treatment arms, 92% in the tacrolimus group and 90% in the cyclosporine group. In the U.S. trial, patient and graft survival at 12 months was similar with 93% survival in the Prograf plus MMF group and 86% survival in the cyclosporine modified plus MMF group. In the European trial, the cyclosporine trough concentrations were above the pre-defined target range (i.e., 100 to 200 ng/mL) at Day 122 and beyond in 32 to 68% of the patients in the cyclosporine treatment arm, whereas the tacrolimus trough concentrations were within the pre-defined target range (i.e., 5 to 15 ng/mL) in 74 to 86% of the patients in the tacrolimus treatment arm. Data from this European trial indicate that from 1 week to 3 months post-transplant, approximately 80% of patients maintained trough concentrations between 8 to 20 ng/mL and, from 3 months through 18 months post-transplant, approximately 80% of patients maintained trough concentrations between 6 to 18 ng/mL.

The U.S. trial contained a third arm of a combination regimen of sirolimus, 2 mg per day, and full-dose Prograf; however, this regimen was associated with increased risk of wound healing complications, renal function impairment, and insulin-dependent post-transplant diabetes mellitus, and is not recommended [see *Warnings and Precautions (5.12)*].

## 16 HOW SUPPLIED/STORAGE AND HANDLING

### 16.1 Prograf (tacrolimus) Capsules USP

|  |  |  |  |
|--|--|--|--|
| <b>strength</b>                        | <b>0.5 mg</b><br>(containing the equivalent of 0.5 mg anhydrous tacrolimus USP)        | <b>1 mg</b><br>(containing the equivalent of 1 mg anhydrous tacrolimus USP)            | <b>5 mg</b><br>(containing the equivalent of 5 mg anhydrous tacrolimus USP)              |
| <b>shape/color</b>                     | oblong/light yellow  | oblong/white   | oblong/grayish red   |
| <b>branding on capsule cap/body</b>    |  607 |  617 |  657 |
| <b>100 count bottle</b>                | <b>NDC 0469-0607-73</b>  | <b>NDC 0469-0617-73</b>  | <b>NDC 0469-0657-73</b>  |
| <b>10 blister cards of 10 capsules</b> | --   | <b>NDC 0469-0617-11</b>  | <b>NDC 0469-0657-11</b>  |

Made in Ireland

Note: Prograf capsules USP are not filled to maximum capsule capacity. Capsule contains labeled amount.

#### Store and Dispense

Store at 25°C (77°F); excursions permitted to 15°C-30°C (59°F-86°F).

### 16.2 Prograf (tacrolimus) Injection

(for IV infusion only)

NDC 0469-3016-01 Product Code 301601

5 mg/mL (equivalent of 5 mg of anhydrous tacrolimus USP per mL) supplied as a sterile solution in a 1 mL ampule, in boxes of 10 ampules

Made in Ireland

#### Store and Dispense

Store between 5°C and 25°C (41°F and 77°F).

## **17 PATIENT COUNSELING INFORMATION**

### **17.1 Administration**

Advise patients to:

- Take Prograf at the same 12-hour intervals everyday to achieve consistent blood concentrations.
- Take Prograf consistently either with or without food because the presence and composition of food decreases the bioavailability of Prograf.
- Not to eat grapefruit or drink grapefruit juice in combination with Prograf [*see Drug Interactions (7.2)*].

### **17.2 Development of Lymphoma and Other Malignancies**

Inform patients they are at increased risk of developing lymphomas and other malignancies, particularly of the skin, due to immunosuppression. Advise patients to limit exposure to sunlight and ultraviolet (UV) light by wearing protective clothing and use a sunscreen with a high protection factor [*see Warnings and Precautions (5.2)*].

### **17.3 Increased Risk of Infection**

Inform patients they are at increased risk of developing a variety of infections, including opportunistic infections, due to immunosuppression and to contact their physician if they develop any symptoms of infection [*see Warnings and Precautions (5.3, 5.4, 5.5)*].

### **17.4 New Onset Diabetes After Transplant**

Inform patients that Prograf can cause diabetes mellitus and should be advised to contact their physician if they develop frequent urination, increased thirst or hunger [*see Warnings and Precautions (5.6)*].

### **17.5 Nephrotoxicity**

Inform patients that Prograf can have toxic effects on the kidney that should be monitored. Advise patients to attend all visits and complete all blood tests ordered by their medical team [*see Warnings and Precautions (5.7)*].

### **17.6 Neurotoxicity**

Inform patients that they are at risk of developing adverse neurologic effects including seizure, altered mental status, and tremor. Advise patients to contact their physician should they develop vision changes, deliriums, or tremors [*see Warnings and Precautions (5.8)*].

### **17.7 Hyperkalemia**

Inform patients that Prograf can cause hyperkalemia. Monitoring of potassium levels may be necessary, especially with concomitant use of other drugs known to cause hyperkalemia [*see Warnings and Precautions (5.9)*].

### **17.8 Hypertension**

Inform patients that Prograf can cause high blood pressure which may require treatment with anti-hypertensive therapy [*see Warnings and Precautions (5.10)*].

### **17.9 Drug Interactions**

Instruct patients to tell their health care providers when they start or stop taking all the medicines, including prescription medicines and non-prescription medicines, natural or herbal remedies, nutritional supplements and vitamins [*see Drug Interactions (7)*].

### **17.10 Pregnant Women and Nursing Mothers**

Instruct patients to tell their healthcare provider if they plan to become pregnant or breast-feed their infant [*see Use in Specific Populations (8.1, 8.3)*]

### **17.11 Immunizations**

Inform patients that Prograf can interfere with the usual response to immunizations and that they should avoid live vaccines [*see Warnings and Precautions (5.16)*].

### **Rx only**

Product of Japan

Manufactured by:

**Astellas Ireland Co., Ltd.**

Killorglin, County Kerry, Ireland

Marketed by:

**Astellas Pharma US, Inc.**

Northbrook, IL 60062

Revised: May 2015

15B012-PRG-WPI

## Patient Information

### **PROGRAF [PRO-graf] (tacrolimus) capsules USP**

Read this Patient Information before you start taking PROGRAF and each time you get a refill. There may be new information. This information does not take the place of talking with your doctor about your medical condition or your treatment.

#### **What is the most important information I should know about PROGRAF?**

##### **Prograf can cause serious side effects, including:**

- 1. Increased risk of cancer.** People who take Prograf have an increased risk of getting some kinds of cancer, including skin and lymph gland cancer (lymphoma).
- 2. Increased risk of infection.** PROGRAF is a medicine that affects your immune system. Prograf can lower the ability of your immune system to fight infections. Serious infections can happen in people receiving Prograf that can cause death. **Call your doctor right away if you have symptoms of an infection such as:**
  - fever
  - sweats or chills
  - cough or flu-like symptoms
  - muscle aches
  - warm, red, or painful areas on your skin

#### **What is PROGRAF?**

PROGRAF is a prescription medicine used with other medicines to help prevent organ rejection in people who have had a kidney, liver, or heart transplant and PROGRAF is not for use with medicines called cyclosporines (Gengraf<sup>®</sup>, Neoral<sup>®</sup>, and Sandimmune<sup>®</sup>).

PROGRAF is not for use with a medicine called sirolimus (Rapamune<sup>®</sup>) in people who have had a liver or heart transplants.

It is not known if PROGRAF is safe and effective when used with sirolimus in people who have had kidney transplants.

It is not known if PROGRAF is safe and effective in children who have had a kidney or heart transplants.

#### **Who Should Not Take PROGRAF?**

**Do not take PROGRAF if you** are allergic to tacrolimus or any of the ingredients in PROGRAF. See the end of this leaflet for a complete list of ingredients in PROGRAF.

## What should I tell my doctor before taking PROGRAF?

### Before you take PROGRAF, tell your doctor if you:

- plan to receive any live vaccines
- have or have had liver, kidney or heart problems
- are pregnant or plan to become pregnant. PROGRAF may harm your unborn baby. Talk to your doctor if you are pregnant or plan to become pregnant.
- Are breastfeeding or plan to breastfeed. PROGRAF can pass into your breast milk. You and your doctor should decide if you will take PROGRAF or breastfeed. You should not do both.

**Tell your doctor about all the medicines you take**, including prescription and non-prescription medicines, vitamins, and herbal supplements.

Especially tell your doctor if you take:

- cyclosporine (Gengraf<sup>®</sup>, Neoral<sup>®</sup>, and Sandimmune<sup>®</sup>)
- sirolimus (Rapamune<sup>®</sup>)
- nelfinavir (Viracept<sup>®</sup>)
- telaprevir (Incivek<sup>™</sup>)
- boceprevir (Victrelis<sup>™</sup>)
- amiodarone (Cordarone<sup>™</sup>, Nexterone<sup>™</sup>, Pacerone<sup>™</sup>)

Ask your doctor or pharmacist if you are not sure if you take any of the medicines listed above.

PROGRAF may affect the way other medicines work, and other medicines may affect how PROGRAF works.

Know the medicines you take. Keep a list of your medicines and show it to your doctor and pharmacist when you get a new medicine.

## How Should I Take PROGRAF?

- Take PROGRAF exactly as your doctor tells you to take it.
- Your doctor will tell you how many PROGRAF to take and when to take them.
- Your doctor may change your PROGRAF dose if needed. **Do not** stop taking or change your dose of PROGRAF without talking to your doctor.
- Take PROGRAF with or without food.
- Take PROGRAF the same way everyday. For example, if you choose to take PROGRAF with food, you should always take PROGRAF with food.
- Take PROGRAF at the same time each day, 12 hours apart. For example, if you take your first dose at 7:00 a.m. you should take your second dose at 7:00 p.m.
  - Taking PROGRAF at the same time each day helps to keep enough medicine in your body to give your transplanted organ the around-the-clock medicine it needs.
- **Do not** eat grapefruit or drink grapefruit juice while taking PROGRAF.
- If you take too much PROGRAF, call your doctor or go to the nearest hospital emergency room right away.



### What should I avoid while taking PROGRAF?

- While you take PROGRAF you should not receive any live vaccines such as:
  - flu vaccine through your nose
  - measles
  - mumps
  - rubella
  - polio by mouth
  - BCG (TB vaccine)
  - yellow fever
  - chicken pox (varicella)
  - typhoid
- Avoid exposure to sunlight and UV light such as tanning machines. Wear protective clothing and use a sunscreen.

### What are the possible side effects of PROGRAF?

#### PROGRAF may cause serious side effects, including:

- See “**What the most important information I should know about PROGRAF?**”
- **high blood sugar (diabetes).** Your doctor may do certain tests to check for diabetes while you take PROGRAF. Call your doctor right away if you have:
  - frequent urination
  - increased thirst or hunger
  - blurred vision
  - confusion
  - drowsiness
  - loss of appetite
  - fruity smell on your breath
  - nausea, vomiting, or stomach pain
- **kidney problems.** Your doctor may do certain tests to check your kidney function while you take PROGRAF.
- **nervous system problems.** Call your doctor right away if you get any of these symptoms while taking PROGRAF. These could be signs of a serious nervous system problem:
  - confusion
  - coma
  - muscle tremors
  - numbness and tingling
  - headache
  - seizures
  - vision changes
- **high levels of potassium in your blood.** Your doctor may do certain tests to check your potassium level while you take PROGRAF.
- **high blood pressure.** Your doctor will monitor your blood pressure while you take PROGRAF.
- **heart problems (myocardial hypertrophy).** Tell your doctor right away if you get any of these symptoms of heart problems while taking PROGRAF:
  - shortness of breath
  - chest pain
  - feel lightheaded
  - feel faint

**The most common side effects of PROGRAF in people receiving kidney transplant are:**

- infection
- tremors (shaking of the body)
- high blood pressure
- kidney problems
- constipation
- diarrhea
- headache
- stomach pain
- trouble sleeping
- nausea
- low levels of phosphate in your blood
- swelling of the hands, ankles, or legs
- weakness
- pain
- high levels of fat in your blood
- high levels of potassium in your blood
- low red blood cell count (anemia)

**The most common side effects of PROGRAF in people receiving liver transplants are:**

- shaking of the body tremors
- headache
- diarrhea
- high blood pressure
- nausea
- kidney problems
- stomach pain
- trouble sleeping
- numbness or tingling in your hands or feet
- anemia
- pain
- fever
- weakness
- high levels of potassium in the blood
- low levels of magnesium in the blood

**The most common side effects of PROGRAF for heart transplant patients are:**

- kidney problems
- high blood pressure

Tell your doctor if you have any side effect that bothers you or that does not go away.

These are not all the possible side effects of PROGRAF. For more information, ask your doctor or pharmacist.

Call your doctor for medical advice about side effects. You may report side effects to FDA at 1-800-FDA-1088.

### **How should I store PROGRAF?**

- Store PROGRAF at 59° F to 86°F (15°C to 30° C).
- Safely throw away medicine that is out of date or no longer needed.

### **Keep PROGRAF and all medicines out of reach of children.**

### **General information about the safe and effective use of PROGRAF**

Medicines are sometimes prescribed for purposes other than those listed in a Patient Information leaflet. Do not use PROGRAF for a condition for which it was not prescribed. Do not give PROGRAF to other people, even if they have the same symptoms that you have. It may harm them.

### **How Does PROGRAF Protect My New Organ?**

The body's immune system protects the body against anything that it does not recognize as part of the body. For example, when the immune system detects a virus or bacteria it tries to get rid of it to prevent infection. When a person has a liver, kidney, or heart transplant, the immune system does not recognize the new organ as a part of the body and tries to get rid of it, too. This is called "rejection". PROGRAF protects your new organ by slowing down the body's immune system.

This Patient Information leaflet summarizes the most important information about PROGRAF. If you would like more information, talk with your doctor. You can ask your pharmacist or doctor for information about PROGRAF that is written for health professionals.

For more information, go to [www.astellas.com/us](http://www.astellas.com/us) or call 1-800-727-7003.

### **What are the ingredients in PROGRAF?**

Active ingredient: tacrolimus

Inactive ingredients: lactose monohydrate, hypromellose, croscarmellose sodium, magnesium stearate, gelatin, titanium dioxide and ferric oxide.

**This Patient Information has been approved by the U.S. Food and Drug Administration.**

### **Product of Japan**

Manufactured by:

**Astellas Ireland Co., Ltd.**

Killorglin, County Kerry, Ireland

Marketed by:

**Astellas Pharma US, Inc.**

Northbrook, IL 60062

Revised: May 2015

15B012-PRG-PPI-WPI